

Design
Engineering
with igubal®

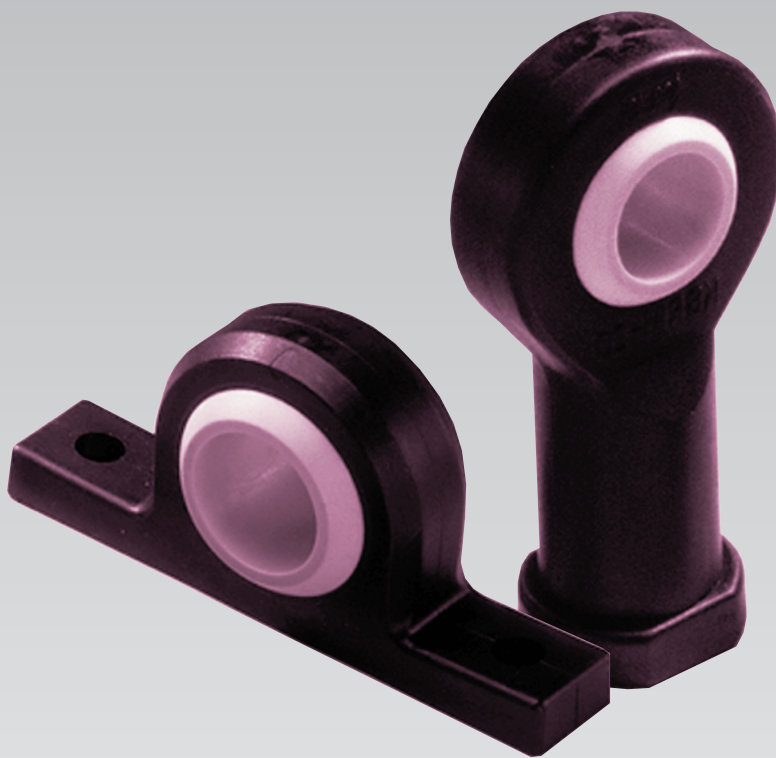

▶ igubal®

Spherical bearings made of high performance plastics	P. 27.4
igubal® Spherical Balls	P. 27.4
igubal® housing made of igumid G	P. 27.4
Loads	P. 27.5
Coefficients of Sliding Friction and Speed	P. 27.5
Application Temperatures	P. 27.5
Chemical Resistance	P. 27.5
Radiation Resistance	P. 27.6
UV Resistance	P. 27.6

igubal® Overview

igubal® Rod End Bearings

igubal® Clevis Joints

igubal® Pillow Blocks



KARI- ...
KALI- ...
Page 28.6



EBRM- ...
EBLM- ...
Page 28.18



KBRI- ...
KBLI- ...
Page 28.7



EARM HT- ...
EALM HT- ...
Page 28.20



EBRI- ...
EBLI- ...
Page 28.8



EBRM HT- ...
EBLM HT- ...
Page 28.21



KARM- ...
KALM- ...
Page 28.10
KARM-...(MH)
KALM-...(MH)
Page 28.10



PKRM- ...
PKLM- ...
Page 28.22

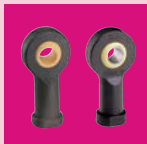

KBRM- ...
KBLM- ...
Page 28.12
KBRM-...(MH)
KBLM-...(MH)
Page 28.12



WGRM- ...
AGRM- ...
Page 28.23

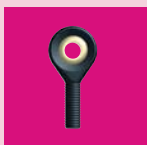

KARM CL- ...
Page 28.14

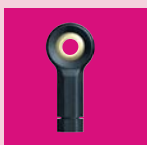

KBRM CL- ...
Page 28.15

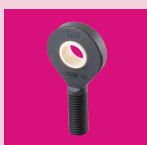

EARM- ...
EALM- ...
Page 28.16



GERI- ...
GELI- ...
Page 29.3
GERM- ...
GELM- ...
Page 29.4



GERMKE- ...
GELMKE- ...
Page 29.5



GEFM- ...
Page 29.5



GBI- ...
GBM- ...
Page 29.6



GSR- ...
Page 29.6

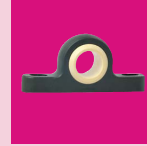

KSTI- ...
Page 30.4
KSTM- ...
Page 30.5



KSTM-GT...
Page 30.6

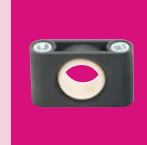

ESTM- ...
Page 30.7

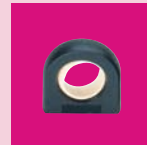

ESTM-SL...
Page 30.8

igubal®
Flange Bearings

igubal®
Pivoting Bearings

igubal®
Thrust Washers

igubal®
Spherical Balls



EFSI-...
Page 31.4
EFSM-...
Page 31.5



EFOI-...
Page 31.6
EFOM-...
Page 31.7



KFSM-GT...
Page 31.8



EFOM HT-...
2-hole
Series E
metric
Page 31.9



EFSM HT-...
4-hole
Series E
metric
Page 31.10

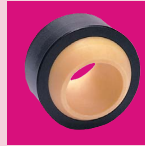

KGLI-...
Page 32.3
KGLM-...
Page 32.4
EGLM-...
Page 32.5

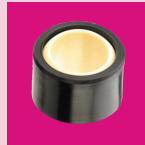

KGLM
Slimline
Series K
metric
Page 32.6



KGLM-...
Low Cost
Page 32.7

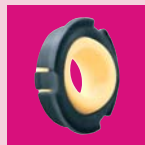

ECLM-...
Clip
Page 32.8

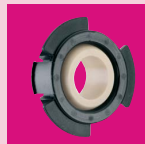

ECLM-...
Clip
Heavy Duty
Page 32.9



EGFM-...
Page 32.10

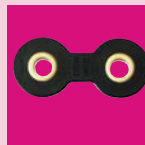

EGZM-...
Page 32.11



SAM-...
Page 34.3

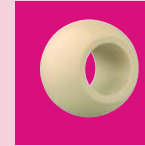

WKM-...
WKI-...
Series K, E
metric/inches
Page 57.3

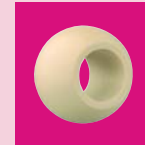

WEM-...
WEI-...
Series K, E
metric/inches
Page 57.3

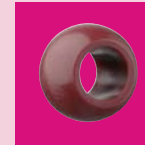

RKM-...
REM-...
Series K, E
metric
Page 57.4

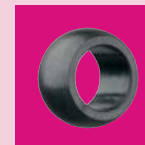

XKM-...
XEM-...
Series K, E
metric
Page 57.4

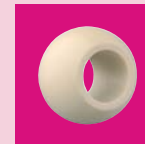

JKM-...
JEM-...
Series K, E
metric
Page 57.5

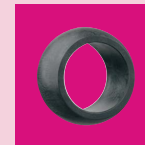

UWEM-...
Series E
metric
Page 57.5



J4VEM-...
Series E
metric
Page 57.6

igubal® self-aligning maintenance-free plain bearings made of high-performance plastics

igubal® puts a complete system of self-aligning bearing elements — spherical bearings, pillow block spherical bearings and rod end bearings — at the developer's fingertips. Self-aligning bearings are easy to install, adapt to all angular deviations and replace special housings in many cases.

With igubal®, the user can take advantage of all the benefits of high-performance plastics: vibration dampening, ability to operate in liquids or chemicals, and resistance to dirt and dust which can impede the performance of greased metal components.

They are very lightweight: 80% lighter than steel. They save on installation space because of their small dimensions, and can save on cost at the time of purchase and in operation.

igubal® bearings are also extremely cost competitive due to the elimination of maintenance and installation costs.

Advantages of igubal®

- cost-effective
- maintenance-free
- lubrication-free
- resistant to dust and dirt
- corrosion-free
- can be used in liquid media
- vibration dampening
- inner race set in housings with very low clearance
- dirt can become embedded for shaft protection

igubal® Spherical Balls

In the igubal® K series the standard spherical ball is made out of iglide® L280 material.

In the igubal® E series the standard spherical ball is made out of either the iglide® L280 or the iglide® R material. Additionally, the design of the igubal E series allows for specials to be made in any of the iglide materials to utilize their unique advantages.

Spherical balls made from the iglide® L280 material are known for its low coefficient of friction while running dry and extremely low tendency to stick-slip. This is especially important for low loads and very slow movements.

Spherical balls made from the iglide® R material offer a cost advantage and low moisture absorption while still maintaining a low coefficient of friction.

Advantages:

- tough, resistant thermoplastic alloy
- very low coefficients of friction while running dry
- high service life
- vibration dampening
- very good abrasion resistance
- excellent wear resistance
- Maintenance-free
- very good chemical resistance
- suitable for rotating, oscillating and linear movements
- also suitable for soft shafts

igubal® housing made of igumid G

The housings are made out of igumid G, a highly shock-resistant, long fiber-reinforced plastic.

Advantages:

- lightweight
- high mechanical strength
- shock and impact resistant
- corrosion-free
- chemically resistant
- dimensionally stable



Some models of the igubal® product line



igubal® flange bearings in reflector telescopes at La Palma, Spain, in the adjustment of the individual reflectors



igubal® rod end bearings in the cylinder-controlled steps of an RV



igubal® flange bearings as drive bearings in a conveyor system for bakery products

Loads

The load capacity of the maintenance-free igubal® bearing elements is very high at normal ambient temperatures. igubal® bearing elements absorb high forces and weigh only a fifth of traditional, metal bearing housings. The excellent dampening properties are based on the fact that the plastic material of the two-part bearing can absorb vibrations differently than steel.

However, plastic-specific properties, such as temperature and behavior under long-time stressing, must be taken into consideration when using igubal® bearings. The load capacity should therefore be checked in a performance test, particularly if they are to be used under continuous high loads and at elevated temperatures.

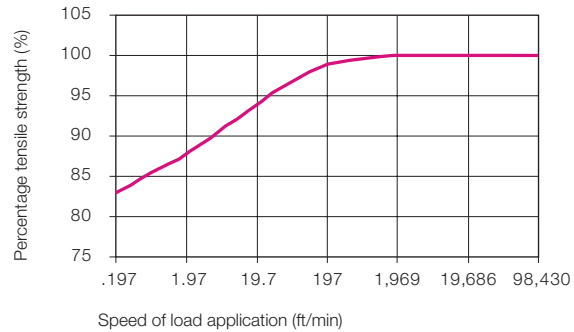

Effect of the speed of load application on the maximum tensile strength of igubal® rod end bearings

Coefficients of Sliding Friction and Speed

One important advantage of igubal® spherical bearings is that rapid, rotary movements of a mounted shaft take place directly in the spherical portion. In metallic rod ends, rotary motion takes place between the race and the spherical bearing. High speeds can be achieved with igubal® bearings.

igubal® bearings are used in such a way that the angular movements of the spherical bearings takes place at the outer diameter. In contrast, rotations of the shaft are supported directly in the I.D. of the spherical portion. The advantage, therefore, lies in the plastic vs. steel relationship. Plastic produces lower friction and permits high speeds, even when running dry.

Application Temperatures

igubal® bearing elements can be used in temperatures from -22 to 176°F. The chart shows the effect of temperature on the load capacity of the igubal® bearing elements.

Application Temperatures

Minimum	-	22°F
Maximum, long-term	+	176°F
Maximum, short-term	+	248°F

Applications temperatures of igubal® bearing elements

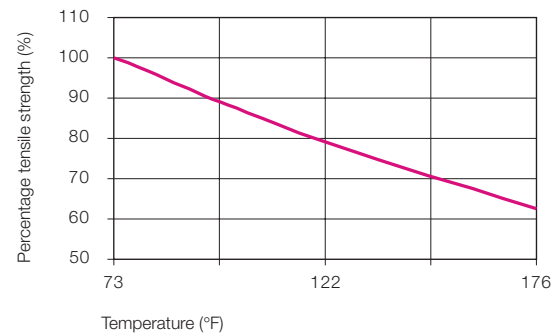

Effect of the temperature on the maximum tensile strength of igubal® rod end bearings

Chemical Resistance

Both the spherical ball made of iglide® L280 and the housing made of igumid G are resistant to weak lyes, weak acids and fuels, as well as all types of lubricants. You will find a chemicals table starting on Page 1.16. The moisture absorption of igubal® with iglide L280 is approximately 1.3% of weight in standard atmosphere. The saturation limit in water is 6.5%. The moisture absorption of igubal® with iglide® R is approximately .2% of weight in standard atmosphere. The saturation in water is 1.1%. This must be taken into account for these types of applications.

Medium	Resistance
Alcohol	Resistant
Chlorinated hydrocarbons	Resistant
Ester	Not Resistant
Greases, oils	Resistant
Ketones	Conditionally Resistant
Fuels	Resistant
Weak acids	Conditionally Resistant
Strong acids	Not Resistant
Weak lyes	Resistant
Strong lyes	Conditionally Resistant

Chemical resistance of igubal® bearing elements



Radiation Resistance

Self-aligning igubal® plain bearings are resistant to radiation up to an intensity of 3×10^2 Gy.

UV Resistance

The corrosion resistance of the igubal® bearings give them special value for outside applications. igubal® bearing elements are permanently resistant to UV radiation. A small change in color (dark coloration) of the spherical ball due to UV radiation does not effect the mechanical, electrical or thermal properties.

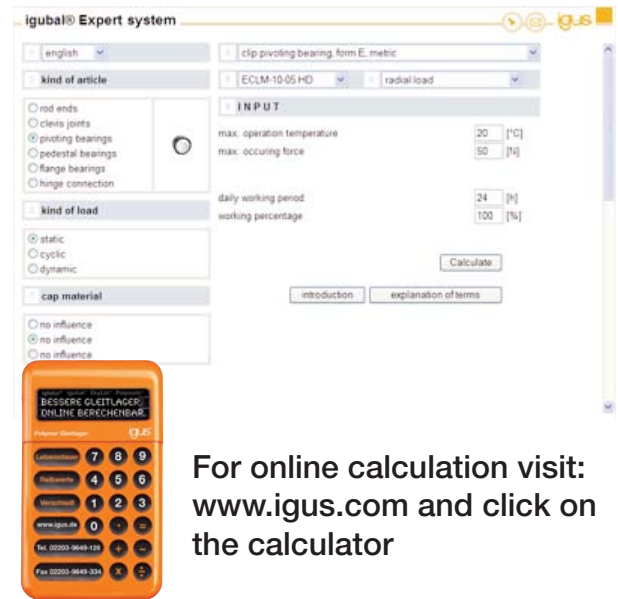

For online calculation visit:
www.igus.com and click on
 the calculator

Areas of Application

igubal® bearing elements can be used without problems even in harsh environments. In moist or wet environments, the bearings are corrosion-resistant, and resistant to weak acids and lyes. The application temperatures range from -22 to 176°F. Resistance to dirt and dust is outstanding.

Seals are not necessary, even in extremely contaminated conditions. This is true for fine dust as well as coarse dirt, which is present in agricultural equipment. The housing is made of an impact-resistant composite material which tolerates high alternating loads.



igubal® rod end bearings in the spring loaded rear axle of a bicycle



igubal® rod end bearing and spherical ball in a linear position sensor



igubal® flange bearings in the drive shaft of an outdoor cleaning machine

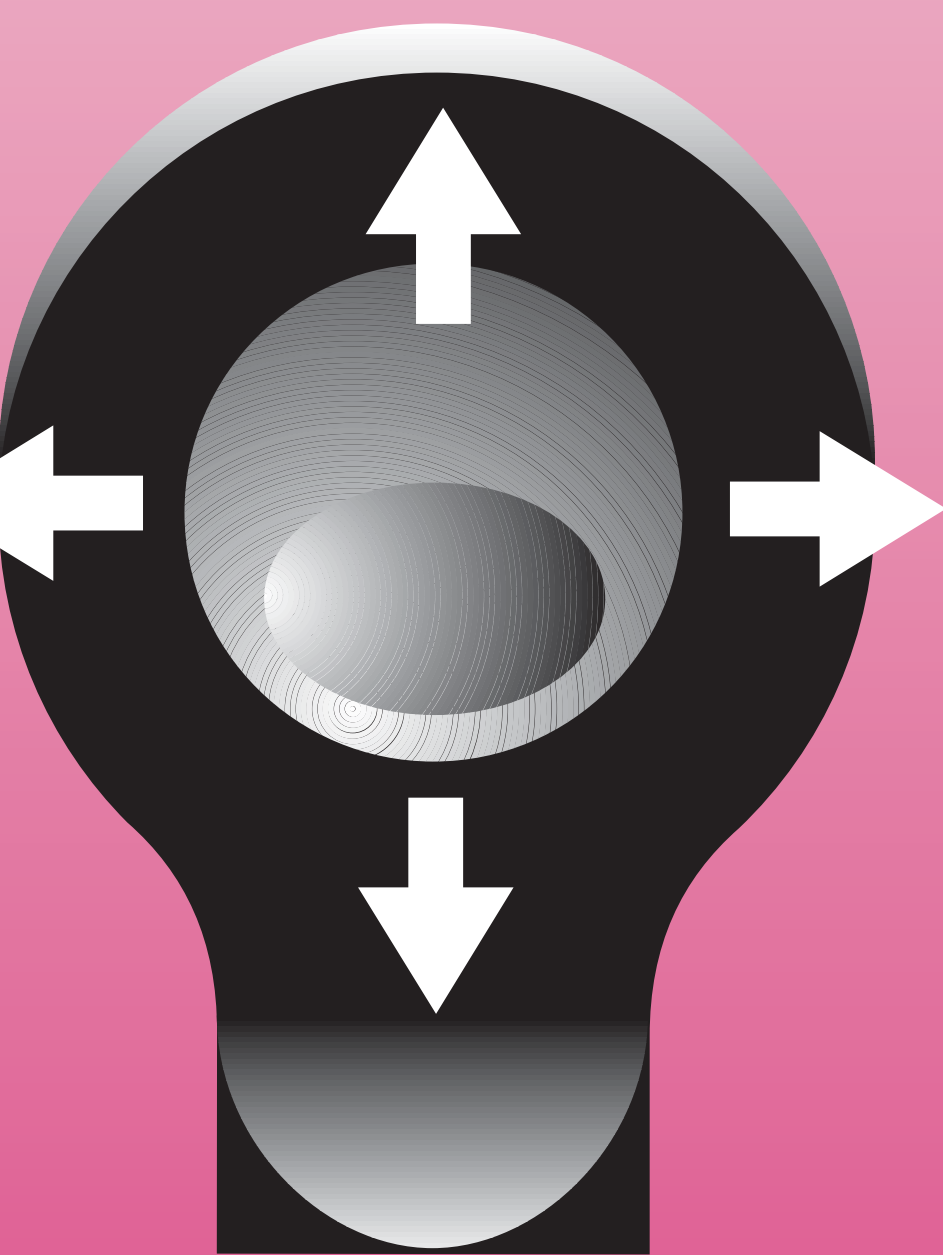

igubal[®] Rod End Bearings

- Maintenance-free, self-lubricating
- High strength under impact loads
- High tensile strength
- Compensation for alignment errors
- Compensation for edge loads
- Lightweight



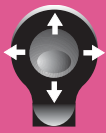

Special properties of igubal[®] Rod End Bearings:

- maintenance-free
- high strength under impact loads
- very high tensile strength for varying loads
- compensation for alignment errors
- compensation for edge loads
- resistant to dirt, dust and lint
- resistant to corrosion and chemicals
- high vibration dampening capacity
- suitable for rotating, oscillating and linear movements
- lightweight
- dimensional series K and E, dimensions according to standard DIN ISO 12240



Loads

igubal[®] rod end bearings handle high loads at normal room temperatures, have excellent dampening properties and weigh only a fifth of traditional metallic rod end bearings. In applications with high continuous loads and high temperatures, the loading capacity of igubal[®] rod end bearings should be tested in an experiment that duplicates the application.

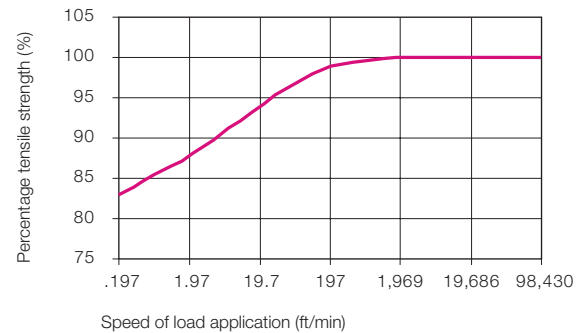

Effect of the speed of load application on the maximum tensile strength of igubal[®] rod end bearings

Coefficients of Friction and Speed

One important advantage of igubal[®] spherical bearings is that rapid, rotary movements of a mounted shaft take place directly in the spherical portion. In metallic rod ends, rotary motion takes place between the race and the spherical bearing. High speeds can be achieved with igubal[®] bearings.

igubal[®] bearings are used in such a way that the angular movements of the spherical bearings take place at the spherical outer diameter. In contrast, rotations of the shaft are supported directly in the inner diameter of the spherical portion. The advantage, therefore, lies in the plastic vs. steel relationship. Plastic produces lower friction and permits high speeds, even when running dry.

The maintenance-free igubal[®] bearing system is also suited for linear and oscillating shaft movements.

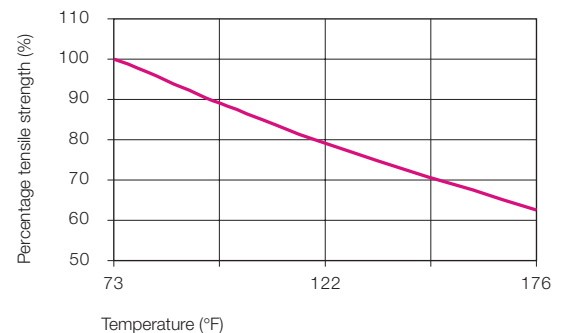

Effect of the temperature on the maximum tensile strength of igubal[®] rod end bearings

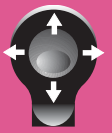

Product Range

igubal® rod end bearings are available in the dimensional series K and E for shaft diameters of .1875" to 1.00" (2 to 30 mm).

- Type A - with outer threads
- Type B - with inner threads

The dimensional series K is available in inch dimensions, as well as a special version containing a stainless steel sleeve in the inner race. This allows a significantly higher torque than for the standard plastic race.

Please ask us about quantities, availability and pricing.



igubal® rod end bearings in the spring loaded rear axle rocker of a bicycle

Tolerances

igubal® rod end bearings can be used at different tolerances depending on the individual application. As a standard program, they are designed with a large amount of bearing clearance, which permits secure operation even at high rotational speeds. The bore of the inner race is produced within a standard tolerance range. Shafts should also meet recommended tolerances. Please contact us with any questions regarding tolerances.

► Tolerance Table, Page 1.14

Thread Name	Pitch (mm)
M 2	0.40
M 3	0.50
M 4	0.70
M 5	0.80
M 6	1.00
M 8	1.25
M 10	1.50
M 10 F	1.25
M 12	1.75
M 12 F	1.25
M 14	2.00
M 16	2.00
M 16 F	1.50
M 18	1.50
M 20	2.50
M 20 M 20	1.50
M 22	1.50
M 24	2.00
M 27	2.00
M 30	2.00

Thread pitches of the igubal® rod end bearings

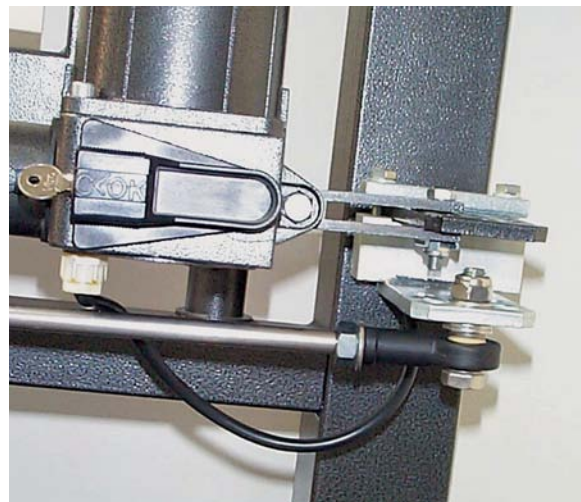

igubal® rod end bearings in the closing mechanism of an outdoor security gate

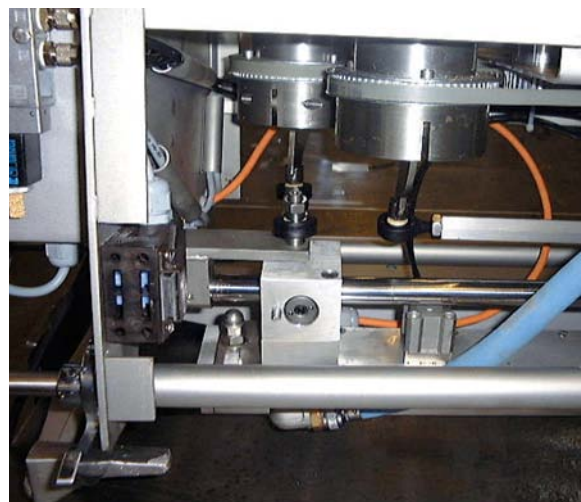

igubal® rod end bearings in a candy decorating machine

PDF: www.igus.com/pdf/igubal.asp
 Specs/CAD/RFQ: www.igus.com/igubal.asp
 RoHS info: www.igus.com/RoHS.asp

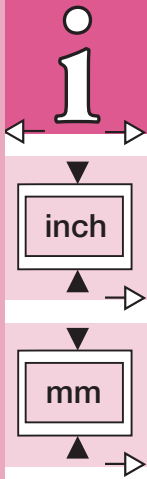

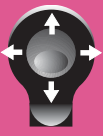

Inch Dimensions - Outer Thread



KARI
KALI
Series K
Standard design with inch dimensions
Page 28.6

Inch Dimensions - Inner Thread



KBRI
KBLI
Series K
Standard design with inch dimensions
Page 28.7



EBRI
EBLI
Series E
Standard design with inch dimensions
Page 28.8

Metric Dimensions - Outer Thread



KARM
KALM
Series K
Standard design
Page 28.10



KARM
KALM
Series K
Standard design with metal sleeve (MH)
Page 28.10



KARM CL
Series K
2nd generation
Page 28.14



EARM
EALM
Series E
Page 28.16



EARM HT
EALM HT
Series E
High Temperature
Page 28.20

Metric Dimensions - Inner Thread



KBRM
KBLM
Series K
Standard design
Page 28.12



KBRM
KBLM
Series K
Standard design with metal sleeve (MH)
Page 28.12



KBRM CL
Series K
2nd generation
Page 28.15



EBRM
EBLM
Series E
Page 28.18



EBRM HT
EBLM HT
Series E
High Temperature
Page 28.21

igubal[®] Accessories for Rod End Bearings



PKRM
PKLM
Adapter bolt
Page 28.22



WGRM
Ball and Socket Joint (ellbow)
Page 28.23



AGRM
Ball and Socket Joint (axial)
Page 28.23



Clevis joint
with clevis pin and circlip
Page 29.3



Clevis joint
with spring-loaded pins
Page 29.5

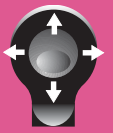

Structure for Part Numbers for igubal® Rod End Bearings

The part numbers of igubal® rod end bearings are designed according to the following system:

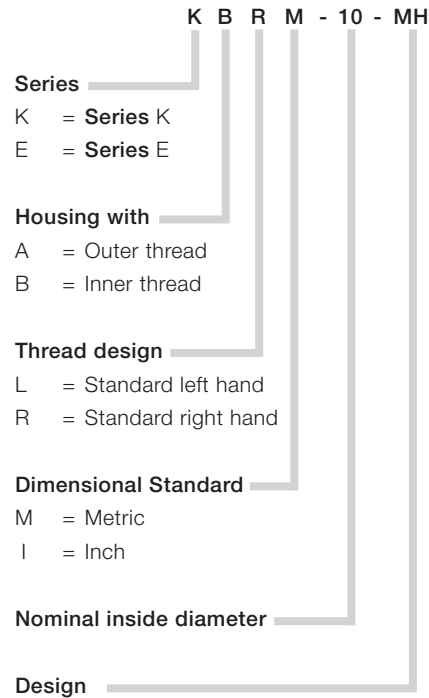

- CL = 2nd generation - only K series offering ability to change spherical ball material
- F = fine thread pitch
- HT = high temperature
- MH = with metal sleeve
- J = with spherical ball made from iglide® J
- J4 = with spherical ball made from iglide® J4
- R = with spherical ball made from iglide® R
- X = with spherical bearing made from iglide® T500

The example given is the number for a rod end bearing of the dimensional series K with metric inner-right threading. The inner diameter of the spherical ball is 10 mm. It is a special design with a metal sleeve.

For the most part, the thread diameter of the bolt corresponds to the inner diameter — here it is M10. However, please pay attention to the following tables.

*The E series bearing is slightly thinner and costs less than its K series counterpart.

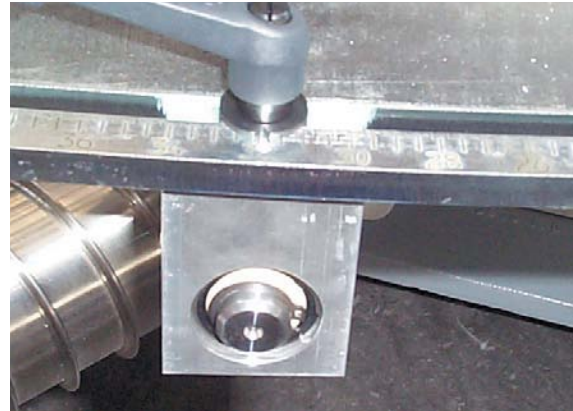

igubal® series E spherical bearings prevent failure as the result of contamination with textile fibers owing to the freedom from maintenance and the fact that lubrication is designed out. One further benefit is the price advantage over metallic products. Part numbers: igubal® spherical bearing EGLM-20



igubal® spherical bearings as an insulating component in current collectors on subways. Pivoting and linear movements in this application are applied to the maintenance-free and corrosion-free high-performance polymers.

Part numbers: igubal® spherical bearing KGLM-22 and rod end bearing KAR(L)M-12

PDF: www.igus.com/pdf/igubal.asp
 Specs/CAD/RFQ: www.igus.com/igubal.asp
 RoHS info: www.igus.com/RoHS.asp

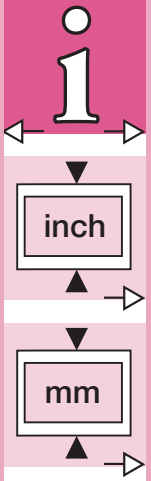



igubal® Rod End Bearings - inch - KARI / KALI

KARI / KALI

igubal® Rod End Bearings



- maintenance-free, self-lubricating
- high strength under impact loads
- very high tensile strength for varying loads
- compensation for alignment errors
- compensation for edge loads
- resistant to dirt, dust and lint
- resistant to corrosion and chemicals
- high vibration dampening capacity
- suitable for rotating, oscillating, and linear movements
- lightweight
- dimensional series K according to standard DIN ISO 12240

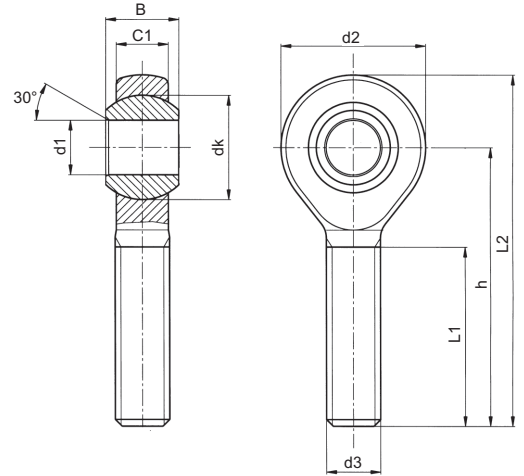

Load Data

Right Thread	Left-Thread	Maximum static Tensile Strength		Maximum Radial Load		Minimum Thread Depth (inch)	Maximum Torque Strength through ball ft lbs	Maximum Thread Strength ft lbs
		Short-term lbs	Long-term lbs	Short-term lbs	Long-term lbs			
KARI-03	KALI-03	87	45	15	7	.525	.37	2.21
KARI-04	KALI-04	202	101	22	11	.700	.74	2.95
KARI-05	KALI-05	247	123	33	16	.875	1.48	7.38
KARI-06	KALI-06	337	168	78	39	.875	2.21	11.06
KARI-07	KALI-07	449	224	89	45	.962	4.43	18.44
KARI-08	KALI-08	562	281	101	50	1.050	6.64	25.82
KARI-10	KALI-10	786	393	134	67	1.137	8.85	36.88
KARI-12	KALI-12	876	438	224	112	1.226	18.44	51.63

Dimensions (inch)

Right-Thread	Left Thread	d1 E10	d2	d3	C1	B	h	L1	L2
KARI-03	KALI-03	.1900	.625	10-32	.234	.312	1.250	.750	1.563
KARI-04	KALI-04	.2500	.750	1/4-28	.250	.365	1.562	1.000	1.937
KARI-05	KALI-05	.3125	.875	5/16-24	.312	.437	1.875	1.250	2.313
KARI-06	KALI-06	.3750	1.000	3/8-24	.359	.500	1.938	1.250	2.438
KARI-07	KALI-07	.4375	1.125	7/16-20	.406	.562	2.125	1.375	2.688
KARI-08	KALI-08	.5000	1.312	1/2-20	.453	.625	2.428	1.500	3.094
KARI-10	KALI-10	.6250	1.500	5/8-18	.484	.750	2.625	1.625	3.375
KARI-12	KALI-12	.7500	1.750	3/4-16	.593	.875	2.875	1.750	3.750

Right-Thread	Left Thread	Shaft		Maximum Angle of Pivot	dk
		Min.	Max.		
KARI-03	KALI-03	.1888	.1900	25°	.438
KARI-04	KALI-04	.2485	.2500	25°	.516
KARI-05	KALI-05	.3110	.3125	25°	.625
KARI-06	KALI-06	.3735	.3750	22°	.718
KARI-07	KALI-07	.4358	.4375	22°	.828
KARI-08	KALI-08	.4983	.5000	22°	.938
KARI-10	KALI-10	.6233	.6250	22°	1.125
KARI-12	KALI-12	.7479	.7500	22°	1.312

Available for delivery

Telephone 1-888-803-1895
Fax 1-401-438-7680

Internet: <http://www.igus.com>
E-Mail: sales@igus.com
QuickSpec: www.igus.com/qs/igubal.asp

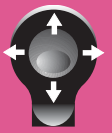

- maintenance-free, self-lubricating
- high strength under impact loads
- very high tensile strength for varying loads
- compensation for alignment errors
- compensation for edge loads
- resistant to dirt, dust and lint
- resistant to corrosion and chemicals
- high vibration dampening capacity
- suitable for rotating, oscillating and linear movements
- very low weight
- dimensional series K according to standard DIN ISO 12240

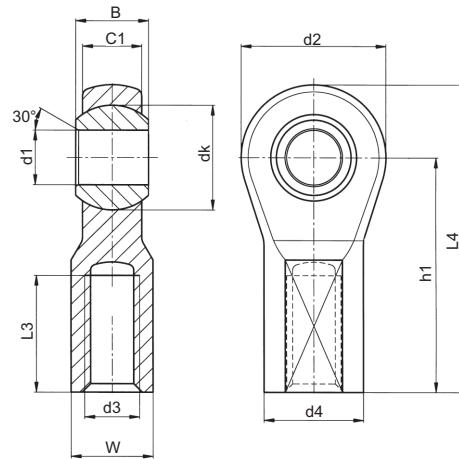

Load Data

Right Thread	Left Thread	Maximum static Tensile Strength		Maximum Radial Load		Minimum Thread Depth (inch)	Maximum Torque Thread Strength ft lbs • force
		Short-term	Long-term	Short-term	Long-term		
		lbs	lbs	lbs	lbs		
KBRI-03	KBLI-03	203	102	67	34	.350	1.47
KBRI-04	KBLI-04	248	124	90	45	.480	3.68
KBRI-05	KBLI-05	383	192	112	56	.480	4.42
KBRI-06	KBLI-06	450	225	225	112	.568	5.16
KBRI-07	KBLI-07	518	259	270	135	.655	13.27
KBRI-08	KBLI-08	585	293	337	169	.743	16.96
KBRI-10	KBLI-10	1103	551	382	191	.962	22.12
KBRI-12	KBLI-12	1260	630	517	259	1.093	29.50
KBRI-16	KBLI-16	1349	674	584	293	1.488	33.92

Dimensions (inch)

Right-Thread	Left Thread	d1 E10	d2	d3	d4	C1	B	h1	L3	L4	W
KBRI-03	KBLI-03	.1900	.625	10-32	.406	.246	.312	1.062	.500	1.374	.312
KBRI-04	KBLI-04	.2500	.750	1/4-28	.469	.272	.365	1.312	.687	1.687	.375
KBRI-05	KBLI-05	.3125	.875	5/16-24	.500	.340	.437	1.375	.687	1.813	.437
KBRI-06	KBLI-06	.3750	1.000	3/8-24	.687	.394	.500	1.625	.812	2.125	.562
KBRI-07	KBLI-07	.4375	1.125	7/16-20	.750	.456	.562	1.812	.937	2.374	.625
KBRI-08	KBLI-08	.5000	1.312	1/2-20	.875	.487	.625	2.125	1.062	2.781	.750
KBRI-10	KBLI-10	.6250	1.500	5/8-18	1.000	.545	.750	2.500	1.375	3.250	.875
KBRI-12	KBLI-12	.7500	1.750	3/4-16	1.125	.676	.875	2.875	1.562	3.750	1.000
KBRI-16	KBLI-16	1.0000	2.750	1-12	1.625	1.000	1.375	4.125	2.125	5.500	1.500

Right-Thread	Left Thread	Shaft		Maximum Angle of Pivot	dk
		Min.	Max.		
KBRI-03	KBLI-03	.1888	.1900	25°	.438
KBRI-04	KBLI-04	.2485	.2500	25°	.516
KBRI-05	KBLI-05	.3110	.3125	25°	.625
KBRI-06	KBLI-06	.3735	.3750	22°	.718
KBRI-07	KBLI-07	.4358	.4375	22°	.828
KBRI-08	KBLI-08	.4983	.5000	22°	.938
KBRI-10	KBLI-10	.6235	.6250	22°	1.125
KBRI-12	KBLI-12	.7479	.7500	22°	1.312
KBRI-16	KBLI-16	.9980	1.000	20°	1.875

Available from stock

igubal® Rod End Bearings
KBRI / KBLI

PDF: www.igus.com/pdf/igubal.asp
Specs/CAD/RFQ: www.igus.com/igubal.asp
RoHS info: www.igus.com/RoHS.asp

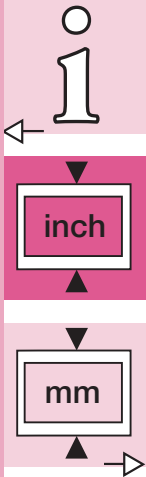

inch

mm

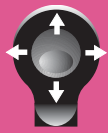

igubal® Rod End Bearings -inch - EBRI / EBLI

EBRI / EBLI

igubal® Rod End Bearings



- standard ball made from iglide® L280, other options are available
- maintenance-free, self-lubricating
- high strength under impact loads
- very high tensile strength for varying loads
- compensation for alignment errors
- compensation for edge loads
- resistant to dirt, dust and lint
- resistant to corrosion and chemicals
- high vibration dampening capacity
- suitable for rotating, oscillating, and linear movements
- lightweight
- dimensional series E according to standard DIN ISO 12240

Telephone 1-888-803-1895
 Fax 1-401-438-7680

Load Data

Right-Thread	Left-Thread	Max. static Tensile Strength		Max. Cross Force		Min. Thread Depth (mm)	Max. Torque Strength Outer Threading (ft lbs)	Max. Torque Strength Through Ball (ft lbs)
		Short-term	Long-term	Short-term	Long-term			
		lbs	lbs	lbs	lbs			
EBRI-03	EBLI-03	292	146	34	17	8	.4	1.5
EBRI-04	EBLI-04	337	168	45	22	8	1.1	1.8
EBRI-05	EBLI-05	449	224	101	51	11	3.7	5.2
EBRI-06	EBLI-06	517	258	112	56	13	11.1	10.3
EBRI-07	EBLI-07	741	370	124	62	14	14.8	18.4
EBRI-08	EBLI-08	741	370	124	62	14	14.8	18.4
EBRI-10	EBLI-10	1079	539	180	90	18	18.4	22.1
EBRI-12	EBLI-12	1618	809	405	202	22	44.3	29.5

Internet: <http://www.igus.com>
 E-Mail: sales@igus.com
 QuickSpec: www.igus.com/qs/igubal.asp

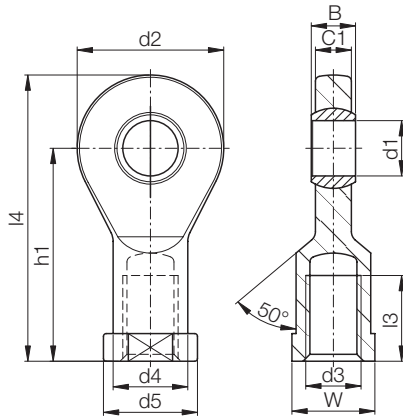
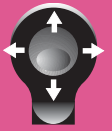

Dimensions (inch)

Right-Thread	Left-Thread	d1 E10	d2	d3	d4	d5	C1	B	h1	l3	l4	W	Max. Angle of Pivot
EBRI-03	EBLI-03	0.1875	0.748	10/32	0.3543	0.4331	0.1732	0.1900	1.1811	0.4724	1.5551	0.35	30°
EBRI-04	EBLI-04	0.2500	0.827	1/4	0.4331	0.5118	0.1732	0.2500	1.1811	0.4724	1.5945	0.43	25°
EBRI-05	EBLI-05	0.3125	0.945	5/16	0.5118	0.6299	0.2362	0.3125	1.4173	0.6299	1.8898	0.55	22°
EBRI-06	EBLI-06	0.3750	1.142	3/8	0.5906	0.7480	0.2756	0.3750	1.6929	0.7087	2.2638	0.67	22°
EBRI-07	EBLI-07	0.4375	1.339	7/16	0.7087	0.8661	0.3150	0.4063	1.9685	0.7874	2.6378	0.75	18°
EBRI-08	EBLI-08	0.5000	1.339	1/2	0.7087	0.8661	0.3150	0.4063	1.9685	0.7874	2.6378	0.75	18°
EBRI-10	EBLI-10	0.6250	1.693	5/8	.827	1.023	0.4134	0.5000	2.5394	1.0433	3.3858	0.87	16°
EBRI-12	EBLI-12	0.7500	2.087	3/4	1.0630	1.3386	0.5118	0.6250	3.0315	1.2205	4.0748	1.18	14°

Available for delivery

► Tolerance Table, Page 1.14

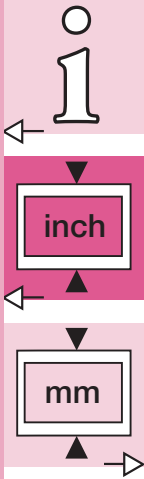

Spherical ball material options ► Page 35.2



RKM:
Low Cost/Low Moisture
Available from stock



XKM: High
temperatures



JKM: Low
moisture absorption



standard spherical ball
with metal sleeve

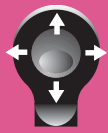

igubal® Rod End Bearings - mm - KARM / KALM

KARM / KALM

igubal® Rod End Bearings



Standard Design



Design with Metal Sleeve (MH)

- maintenance-free self-lubricating
- high strength under impact loads
- very high tensile strength for varying loads
- compensation for alignment errors
- compensation for edge loads
- resistant to dirt, dust and lint
- resistant to corrosion and chemicals
- high vibration dampening capacity
- suitable for rotating, oscillating and linear movements
- lightweight
- dimensional series K according to standard DIN ISO 12240
- design with a metal sleeve in the inner race for increased thread strength

Load Data

Right-Thread	Left-Thread	Max. static Tensile Strength		Max. Radial Load		Min. Thread Depth (mm)	Max. Torque Strength Inner Threading (ft lbs)	Max. Torque Strength	
		Short-term lbs	Long-term lbs	Short-term lbs	Long-term lbs			Without Metal Sleeve	With Metal Sleeve
								ft lbs	ft lbs
KARM-05	KALM-05	180	90	18	9	13	.3	3.7	8.8
KARM-06	KALM-06	225	112	22	11	15	.4	7.4	11.1
KARM-08	KALM-08	382	191	45	22	18	1.5	8.9	29.5
KARM-10	KALM-10	562	281	67	33	20	3.7	14.8	36.9
KARM-10 F	KALM-10 F	562	281	67	33	20	2.2	14.8	36.9
KARM-12	KALM-12	607	303	89	45	22	4.4	22.1	51.6
KARM-12 F	KALM-12 F	607	303	89	45	22	4.4	22.1	51.6
KARM-14	KALM-14	764	382	157	78	25	8.9	25.8	55.3
KARM-16	KALM-16	876	438	179	89	26	12.5	29.5	81.1
KARM-16 F	KALM-16 F	876	438	179	89	26	12.5	29.5	81.1
KARM-18	KALM-18	944	472	224	112	29	14.8	33.2	110.6
KARM-20	KALM-20	1348	674	292	146	32	18.4	40.6	147.5
KARM-20 M20	KALM-20 M20	1348	674	292	146	32	18.4	40.6	147.5
KARM-22	KALM-22	1618	809	337	168	34	18.4	44.3	166.0
KARM-25	KALM-25	1686	843	427	213	39	33.2	47.9	191.8
KARM-30	KALM-30	1978	989	517	258	46	62.7	51.6	221.3

Telephone 1-888-803-1895
Fax 1-401-438-7680

Internet: <http://www.igus.com>
E-Mail: sales@igus.com
QuickSpec: www.igus.com/qs/igubal.asp

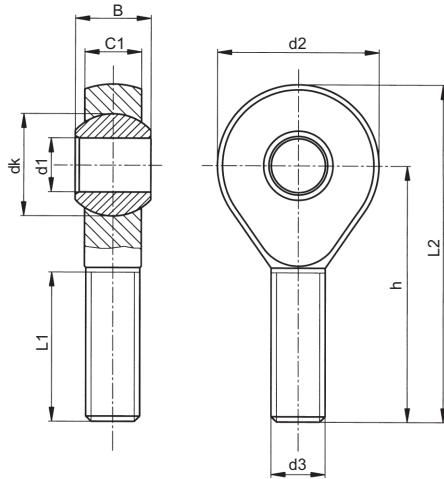
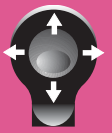

Dimensions (mm)

Right-Thread	Left-Thread	d1 E10	d2	d3	C1	B	h	L1	L2
KARM-05	KALM-05	5	18	M05	6.0	8.0	33	19	42
KARM-06	KALM-06	6	20	M06	7.0	9.0	36	21	46
KARM-08	KALM-08	8	24	M08	9.0	12.0	42	25	55
KARM-10	KALM-10	10	30	M10	10.5	14.0	48	28	63
KARM-10 F	KALM-10 F	10	30	M10 x 1.25	10.5	14.0	48	28	63
KARM-12	KALM-12	12	34	M12	12.0	16.0	54	32	71
KARM-12 F	KALM-12 F	12	34	M12 x 1.25	12.0	16.0	54	32	71
KARM-14	KALM-14	14	38	M14	13.5	19.0	61	36	79
KARM-16	KALM-16	16	42	M16	15.0	21.0	66	37	88
KARM-16 F	KALM-16 F	16	42	M16 x 1.5	15.0	21.0	66	37	88
KARM-18	KALM-18	18	46	M18 x 1.5	16.5	23.0	72	41	96
KARM-20	KALM-20	20	50	M20 x 2.5	18.0	25.0	78	45	104
KARM-20 M20	KALM-20 M20	20	50	M20 x 1.5	18.0	25.0	78	45	104
KARM-22	KALM-22	22	56	M22 x 1.5	20.0	28.0	84	48	112
KARM-25	KALM-25	25	60	M24 x 2.0	22.0	31.0	94	55	125
KARM-30	KALM-30	30	70	M30 x 2.0	25.0	37.0	110	66	147

Right-Thread	Left-Thread	Shaft		Maximum Angle of Pivot	dk
		Min.	Max.		
KARM-05	KALM-05	4.970	5.000	30°	11.10
KARM-06	KALM-06	5.970	6.000	29°	12.70
KARM-08	KALM-08	7.964	8.000	25°	15.80
KARM-10	KALM-10	9.964	10.000	25°	19.00
KARM-10 F	KALM-10 F	9.964	10.000	25°	19.00
KARM-12	KALM-12	11.957	12.000	25°	22.20
KARM-12 F	KALM-12 F	11.957	12.000	25°	22.20
KARM-14	KALM-14	13.957	14.000	25°	25.40
KARM-16	KALM-16	15.957	16.000	23°	28.50
KARM-16 F	KALM-16 F	15.957	16.000	23°	28.50
KARM-18	KALM-18	17.957	18.000	23°	31.70
KARM-20	KALM-20	19.948	20.000	23°	34.90
KARM-20 M20	KALM-20 M20	19.948	20.000	23°	34.90
KARM-22	KALM-22	21.948	22.000	22°	38.10
KARM-25	KALM-25	24.948	25.000	22°	42.80
KARM-30	KALM-30	29.948	30.000	22°	50.80

Rod end bearings can be ordered in metric dimensions with metal sleeve with the addition of MH after the part numbers listed here, i.e. for example: KARM-10 MH Available for delivery

► Tolerance Table, Page 1.14

igubal® Rod End Bearings
KARM / KALM

PDF: www.igus.com/pdf/igubal.asp
Specs/CAD/RFG: www.igus.com/igubal.asp
RoHS info: www.igus.com/RoHS.asp

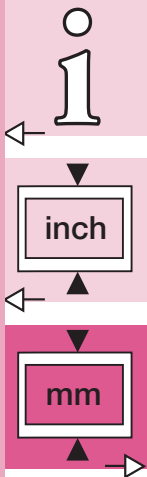

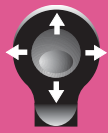

igubal® Rod End Bearings - mm - KBRM / KBLM

KBRM / KBLM

igubal® Rod End Bearings



Standard Design



Design with Metal Sleeve (MH)

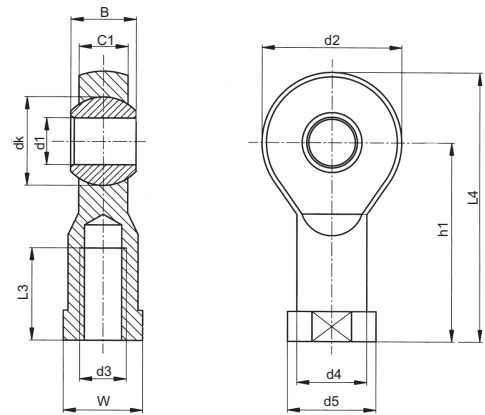

Special properties

- Maintenance-free dry running
- high strength under impact loads
- very high tensile strength for varying loads
- compensation for alignment errors
- compensation for edge loads
- resistant to dirt, dust and lint
- resistant to corrosion and chemicals
- high vibration dampening capacity
- suitable for rotating, oscillating and linear movements
- lightweight
- dimensional series K to standard DIN ISO 12240
- design with a metal sleeve in the inner race for increased torque strength

Load Data

Right-Thread	Left-Thread	Max. static Tensile Strength		Max. Radial Load		Min. Thread Depth (mm)	Max. Torque Strength Inner Threading (ft lbs)	Max. Torque Strength	
		Short-term (lbs)	Long-term (lbs)	Short-term (lbs)	Long-term (lbs)			Without Metal Sleeve (ft lbs)	With Metal Sleeve (ft lbs)
KBRM-02	KBLM-02	134	67	13	6	4	.22	.74	1.5
KBRM-03	KBLM-03	179	89	22	11	5	.37	1.5	3.0
KBRM-05 M4	KBLM-05 M4	224	112	56	28	7	.55	3.7	8.9
KBRM-05	KBLM-05	224	112	56	28	7	.74	3.7	8.9
KBRM-06	KBLM-06	314	157	89	44	8	1.10	7.4	11.1
KBRM-08	KBLM-08	472	236	157	78	11	7.4	8.9	29.5
KBRM-10	KBLM-10	696	348	179	89	13	11.1	14.8	36.9
KBRM-10 F	KBLM-10 F	696	348	179	89	13	4.4	14.8	36.9
KBRM-12	KBLM-12	809	404	202	101	15	14.8	22.1	51.6
KBRM-12 F	KBLM-12 F	809	404	202	101	15	11.1	22.1	51.6
KBRM-14	KBLM-14	899	449	224	112	17	18.4	25.8	55.3
KBRM-16	KBLM-16	944	472	292	146	19	22.1	29.5	81.1
KBRM-16 F	KBLM-16 F	944	472	292	146	19	20.3	29.5	81.1
KBRM-18	KBLM-18	1034	517	359	179	21	33.2	33.2	110.6
KBRM-20	KBLM-20	1213	606	472	236	22	59.0	40.6	147.5
KBRM-20 M20	KBLM-20 M20	1213	606	472	236	22	44.3	40.6	147.5
KBRM-22	KBLM-22	1573	786	494	247	25	55.3	44.3	166.0
KBRM-25	KBLM-25	1910	955	517	258	28	88.5	44.3	191.8
KBRM-30	KBLM-30	2360	1180	562	281	34	99.5	44.3	221.3

Telephone 1-888-803-1895

Fax 1-401-438-7680

Telephone

Fax

Internet: <http://www.igus.com>

E-Mail: sales@igus.com

QuickSpec: www.igus.com/qs/igubal.asp

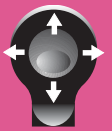

Dimensions (mm)

Right-Thread	Left-thread	d1 E10	d2	d3	d4	d5	C1	B	h1	I3	I4	W
KBRM-02	KBLM-02	2	9	M02	4.0	4.6	3.0	4	12.5	6	17	SW04
KBRM-03	KBLM-03	3	13	M03	6.5	8.0	4.5	6	18.5	8	25	SW06
KBRM-05 M4	KBLM-05 M4	5	18	M04	9.0	12.0	6.0	8	27	10	36	SW09
KBRM-05	KBLM-05	5	18	M05	9.0	12.0	6.0	8	27	10	36	SW09
KBRM-06	KBLM-06	6	20	M06	10.0	13.0	7.0	9	30	12	40	SW11
KBRM-08	KBLM-08	8	24	M08	13.0	16.0	9.0	12	36	16	48	SW14
KBRM-10	KBLM-10	10	30	M10	15.0	19.0	10.5	14	43	20	58	SW17
KBRM-10 F	KBLM-10 F	10	30	M10x1.25	15.0	19.0	10.5	14	43	20	58	SW17
KBRM-12	KBLM-12	12	34	M12	18.0	22.0	12.0	16	50	22	67	SW19
KBRM-12 F	KBLM-12 F	12	34	M12x1.25	18.0	22.0	12.0	16	50	22	67	SW19
KBRM-14	KBLM-14	14	38	M14	20.0	25.0	13.5	19	57	25	76	SW22
KBRM-16	KBLM-16	16	42	M16	22.0	27.0	15.0	21	64	28	85	SW22
KBRM-16 F	KBLM-16 F	16	42	M16x1.5	22.0	27.0	15.0	21	64	28	85	SW22
KBRM-18	KBLM-18	18	46	M18x1.5	25.0	31.0	16.5	23	71	32	94	SW27
KBRM-20	KBLM-20	20	50	M20x2.5	28.0	34.0	18.0	25	77	33	102	SW30
KBRM-20 M20	KBLM-20 M20	20	50	M20x1.5	28.0	34.0	18.0	25	77	33	102	SW30
KBRM-22	KBLM-22	22	56	M22x1.5	30.0	37.0	20.0	28	84	37	112	SW32
KBRM-25	KBLM-25	25	60	M24x2.0	32.0	41.0	22.0	31	94	42	124	SW36
KBRM-30	KBLM-30	30	70	M30x2.0	37.0	50.0	25.0	37	110	51	145	SW41

Right-Thread	Left-Thread	Shaft		Maximum Angle of Pivot	dk
		Min.	Max.		
KBRM-02	KBLM-02	1.975	2.000	30°	5.20
KBRM-03	KBLM-03	2.975	3.000	30°	7.90
KBRM-05 M4	KBLM-05 M4	4.970	5.000	30°	11.10
KBRM-05	KBLM-05	4.970	5.000	30°	11.10
KBRM-06	KBLM-06	5.970	6.000	29°	12.70
KBRM-08	KBLM-08	7.964	8.000	25°	15.80
KBRM-10	KBLM-10	9.964	10.000	25°	19.00
KBRM-10 F	KBLM-10 F	9.964	10.000	25°	19.00
KBRM-12	KBLM-12	11.957	12.000	25°	22.20
KBRM-12 F	KBLM-12 F	11.957	12.000	25°	22.20
KBRM-14	KBLM-14	13.957	14.000	23°	25.40
KBRM-16	KBLM-16	15.957	16.000	23°	28.50
KBRM-16 F	KBLM-16 F	15.957	16.000	23°	28.50
KBRM-18	KBLM-18	17.957	18.000	23°	31.70
KBRM-20	KBLM-20	19.948	20.000	23°	34.90
KBRM-20 M20	KBLM-20 M20	19.948	20.000	23°	34.90
KBRM-22	KBLM-22	21.948	22.000	22°	38.10
KBRM-25	KBLM-25	24.948	25.000	22°	42.80
KBRM-30	KBLM-30	29.948	30.000	22°	50.80

Rod end bearings can be ordered in metric dimensions with metal sleeve with the addition of MH after the part numbers listed here, i.e. for example: KBRM-10 MH
Available for delivery

► Tolerance Table, Page 1.14

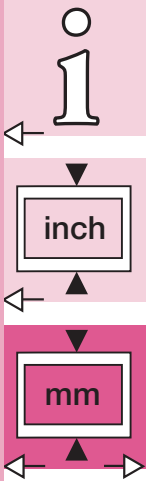



igubal® Rod End Bearings - KARM CL

The new igubal®-rod end bearings have spherical balls made from iglide® L280 as standard. Other materials are optional

KARM CL

igubal® Rod End Bearings

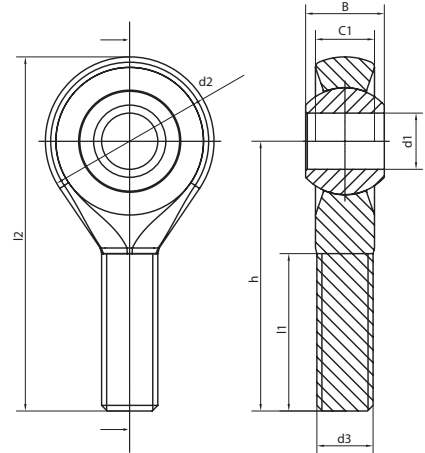

Special properties

- Smooth design has no dirt traps
- Compensation for alignment errors
- Light weight
- Excellent corrosion resistance
- Design with metal isleeve for higher torque strength available
- Left-hand thread version KALM in preparation

Load Data

Part Number	Maximum static tensile strength		Maximum radial load		Minimum thread depth (mm)	Max. torque strength outside thread (lbs · ft)	Max. torque though Ball	
	short-term (lbs)	long-term (lbs)	short-term (lbs)	long-term (lbs)			standard (lbs · ft)	MH (lbs · ft)
KARM-06 CL	225	113	22	11	15	.369	7.376	11.060
KARM-08 CL	382	191	45	22	18	1.475	8.851	29.500
KARM-10 CL	562	281	68	34	20	3.688	14.750	36.880
KARM-12 CL	607	304	90	45	22	4.425	22.130	51.630

Dimensions (mm)

Part Number	d1 E10	d2	d3	C1	B	h	l1	l2	Max. pivot angle
KARM-06 CL	6	20	M06	7.0	9.0	36	21	46	40°
KARM-08 CL	8	24	M08	9.0	12.0	42	25	55	35°
KARM-10 CL	10	30	M10	10.5	14.0	48	28	63	35°
KARM-12 CL	12	34	M12	12.0	16.0	54	32	71	35°

For rod end bearings with metal insert please add **MH** to the part number, e.g. KARM-10 CL **MH**.

For another spherical bearing material please add **J**, **R** or **X** to the part number, e.g. KARM-10 CL **J**.

Spherical ball material options ▶ Page 35.2



RKM:
Low Cost/Low Moisture



XKM: High temperatures



JKM: Low moisture absorption



standard spherical ball with metal sleeve

Telephone 1-888-803-1895
Fax 1-401-438-7680

Telephone 1-888-803-1895
Fax 1-401-438-7680

Internet: <http://www.igus.com>
E-Mail: sales@igus.com
QuickSpec: www.igus.com/qs/igubal.asp

igubal® Rod End Bearings - KBRM CL

The new igubal®-rod end bearings have spherical balls made from iglide® L280 as standard

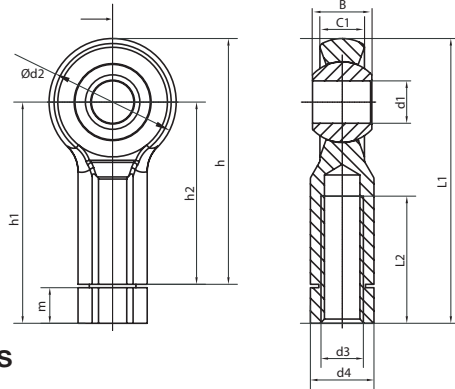

Simple assembly due to the hexagonal body and the integrated lock nut.

Special properties

- Smooth design has no dirt traps
- Compensation for alignment errors
- Light weight
- Excellent corrosion resistance
- Design with metal sleeve for higher torque strength available
- Left-hand thread version KBLM in preparation

Load Data

Part Number	Maximum static tensile strength		Maximum radial load		Minimum thread depth (mm)	Max. torque strength outside thread (lbs · ft)	Max. torque though Ball	
	short-term (lbs)	long-term (lbs)	short-term (lbs)	long-term (lbs)			standard (lbs · ft)	MH (lbs · ft)
KBRM-06 CL	315	158	90	45	8	1.106	7.376	11.060
KBRM-08 CL	473	236	158	79	11	7.376	8.851	29.500
KBRM-10 CL	698	349	180	90	13	11.060	14.750	36.880

Dimensions (mm)

Part Number	d1 E10	d2	d3	d4	B	C1	h	h1	h2	L2	L1	Max. pivot angle
KBRM-06 CL	6	20	M06	SW10	9	7	40	5,7	30	20	46,5	40°
KBRM-08 CL	8	24	M08	SW13	12	9	48	7,5	36	25	56,3	35°
KBRM-10 CL	10	30	M10	SW15	14	10,5	58	52,2	43	30	67,2	35°

For rod end bearings with metal insert please add **MH** to the part number, e.g. KBRM-10 CL **MH**.

For another spherical bearing material please add **J**, **R** or **X** to the part number, e.g. KBRM-10 CL **J**.

Spherical ball material options ▶ Page 35.2



RKM:
Low Cost/Low Moisture



XKM: High
temperatures



JKM: Low
moisture absorption



standard spherical ball
with metal sleeve

igubal® Rod
End Bearings
KBRM CL

PDF: www.igus.com/pdf/igubal.asp
Specs/CAD/RFQ: www.igus.com/igubal.asp
RoHS info: www.igus.com/RoHS.asp

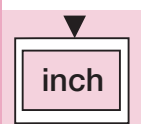

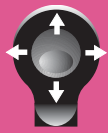

EARM / EALM

igubal® Rod End Bearings

Telephone 1-888-803-1895

Fax 1-401-438-7680

Internet: <http://www.igus.com>

E-Mail: sales@igus.com

QuickSpec: www.igus.com/qs/igubal.asp



Special properties

- maintenance-free, self-lubricating
- high strength under impact loads
- very high tensile strength for varying loads
- compensation for alignment errors
- compensation for edge loads
- resistant to corrosion and chemicals
- high vibration dampening capacity
- suitable for rotating, oscillating, and linear movements
- lightweight
- dimensional series E according DIN ISO 12240

Load Data

Right-Thread	Left-Thread	Max. static Tensile Strength		Max. Radial Load		Min. Thread Depth (mm)	Max. Torque Strength Outer Threading (ft lbs)	Max. Torque Strength Through Ball (ft lbs)
		Short-term	Long-term	Short-term	Long-term			
		lbs	lbs	lbs	lbs			
EARM-05	EALM-05	123	61	11	5	14	.3	1.5
EARM-06	EALM-06	191	95	18	9	14	.4	1.8
EARM-08	EALM-08	359	179	33	16	17	1.5	5.2
EARM-10	EALM-10	584	292	56	28	19	3.7	10.3
EARM-10 F	EALM-10 F	584	292	56	28	19	2.2	10.3
EARM-12	EALM-12	674	337	67	33	20	4.4	18.4
EARM-12 F	EALM-12 F	674	337	67	33	20	4.4	18.4
EARM-15	EALM-15	1011	505	89	45	24	9.2	22.1
EARM-17	EALM-17	1124	562	112	56	26	12.9	25.8
EARM-17 F	EALM-17 F	1124	562	112	56	26	15.5	25.8
EARM-20	EALM-20	1461	730	134	67	30	22.1	29.5
EARM-20 M20	EALM-20 M20	1461	730	134	67	30	18.4	29.5
EARM-25	EALM-25	1910	955	179	89	37	33.2	40.6
EARM-30	EALM-30	2248	1124	224	112	46	62.7	51.6

Spherical ball material options ▶ Page 35.2



RKM: Low Cost/Low Moisture



XKM: High temperatures



JKM: Low moisture absorption



standard spherical ball with metal sleeve

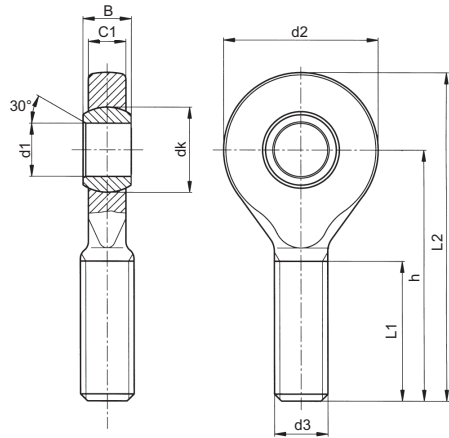
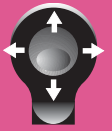

Dimensions (mm)

Right-Thread	Left-Thread	d1 E10	d2	d3	C1	B	h	l1	l2	Max. Angle of Pivot
EARM-05	EALM-05	5	19	M05	4.4	6	36	20	45.5	33°
EARM-06	EALM-06	6	21	M06	4.4	6	36	20	46.5	27°
EARM-08	EALM-08	8	24	M08	6.0	8	41	24	53.0	24°
EARM-10	EALM-10	10	29	M10	7.0	9	47.5	27	62.0	24°
EARM-10 F	EALM-10 F	10	29	M10 x 1.25	7.0	9	47.5	27	62.0	24°
EARM-12	EALM-12	12	34	M12	8.0	10	54	29	71.0	21°
EARM-12 F	EALM-12 F	12	34	M12 x 1.25	8.0	10	54	29	71.0	21°
EARM-15	EALM-15	15	40	M14	10.0	12	63	34	83.0	21°
EARM-17	EALM-17	17	46	M16	11.0	14	69	37	92.0	21°
EARM-17 F	EALM-17 F	17	46	M16 x 1.5	11.0	14	69	37	92.0	18°
EARM-20	EALM-20	20	53	M20 x 1.5	13.0	16	80	43	106.5	16°
EARM-20 M20	EALM-20 M20	20	53	M20 x 2.5	13.0	16	80	43	106.5	16°
EARM-25	EALM-25	25	64	M24 x 2.0	17.0	20	97	53	129.0	16°
EARM-30	EALM-30	30	73	M30 x 2.0	19.0	22	113	65	149.5	13°

Available for delivery

► Tolerance Table, Page 1.14

igubal® Rod End Bearings
EARM / EALM

PDF: www.igus.com/pdf/igubal.asp
Specs/CAD/RFG: www.igus.com/igubal.asp
RoHS info: www.igus.com/RoHS.asp

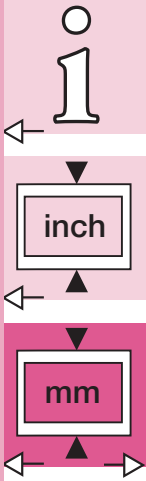

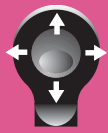

EBRM / EBLM

igubal® Rod End Bearings

Telephone 1-888-803-1895
Fax 1-401-438-7680

Internet: <http://www.igus.com>
E-Mail: sales@igus.com
QuickSpec: www.igus.com/qs/igubal.asp



Special properties

- maintenance-free, self-lubricating
- high strength under impact loads
- very high tensile strength for varying loads
- compensation for alignment errors
- compensation for edge loads
- resistant to dirt, dust and lint
- resistant to corrosion and chemicals
- high vibration dampening capacity
- suitable for rotating, oscillating, and linear movements
- lightweight
- dimensional series E according to standard DIN ISO 12240

Load Data

Right-Thread	Left-Thread	Max. static Tensile Strength		Max. Radial Load		Min. Thread Depth (mm)	Max. Torque Strength Outer Threading (ft lbs)	Max. Torque Strength Through Ball (ft lbs)
		Short-term	Long-term	Short-term	Long-term			
		lbs	lbs	lbs	lbs			
EBRM-04	EBLM-04	180	90	22	11	7	.3	1.5
EBRM-05	EBLM-05	292	146	34	17	8	.4	1.5
EBRM-06	EBLM-06	337	168	45	22	8	1.1	1.8
EBRM-08	EBLM-08	449	224	101	51	11	3.7	5.2
EBRM-10	EBLM-10	517	258	112	56	13	11.1	10.3
EBRM-10 F	EBLM-10 F	517	258	112	56	13	4.4	10.3
EBRM-12	EBLM-12	741	370	124	62	14	14.8	18.4
EBRM-12 F	EBLM-12 F	741	370	124	62	14	11.1	18.4
EBRM-15	EBLM-15	1079	539	180	90	18	18.4	22.1
EBRM-17	EBLM-17	1191	595	247	124	19	22.1	25.8
EBRM-17 F	EBLM-17 F	1191	595	247	124	19	20.3	25.8
EBRM-20	EBLM-20	1618	809	405	202	22	44.3	29.5
EBRM-20 M20	EBLM-20 M20	1618	809	405	202	22	59.0	29.5
EBRM-25	EBLM-25	2248	1124	584	292	27	84.8	40.6
EBRM-30	EBLM-30	2360	1180	674	337	33	95.9	51.6

Spherical ball material options ▶ Page 35.2



RKM:
Low Cost/Low Moisture



XKM: High temperatures



JKM: Low moisture absorption



standard spherical ball with metal sleeve

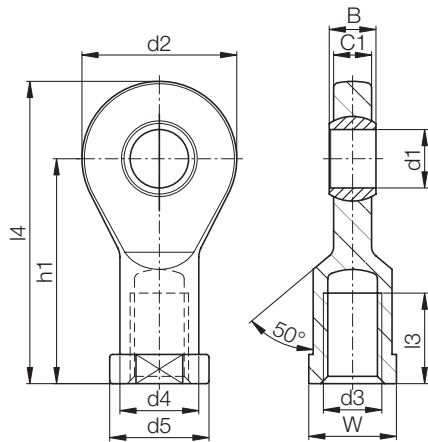
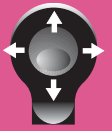

Dimensions (mm)

Right-Thread	Left Thread	d1 E10	d2	d3	d4	d5	C1	B	h1	l3	l4	W	Max. Angle of Pivot
EBRM-04	EBLM-04	4	15	M04	8.0	9.2	3.5	5	22.5	9.5	30.0	SW08	33°
EBRM-05	EBLM-05	5	19	M05	9.0	11	4.4	6	30	12	39.5	SW09	33°
EBRM-06	EBLM-06	6	21	M06	11.0	13	4.4	6	30	12	40.5	SW11	27°
EBRM-08	EBLM-08	8	24	M08	13.0	16	6.0	8	36	16	48.0	SW14	24°
EBRM-10	EBLM-10	10	29	M10	15.0	19	7.0	9	43	18	57.5	SW17	24°
EBRM-10 F	EBLM-10 F	10	29	M10x1.25	15.0	19	7.0	9	43	18	57.5	SW17	24°
EBRM-12	EBLM-12	12	34	M12	18.0	22	8.0	10	50	20	67.0	SW19	21°
EBRM-12 F	EBLM-12 F	12	34	M12x1.25	18.0	22	8.0	10	50	20	67.0	SW19	21°
EBRM-15	EBLM-15	15	40	M14	21.0	26	10.0	12	61	26	81.0	SW22	21°
EBRM-17	EBLM-17	17	46	M16	24.0	30	11.0	14	67	27	90.0	SW27	21°
EBRM-17 F	EBLM-17 F	17	46	M16x1.5	24.0	30	11.0	14	67	27	90.0	SW27	18°
EBRM-20	EBLM-20	20	53	M20x1.5	27.0	34	13.0	16	77	31	103.5	SW30	16°
EBRM-20 M20	EBLM-20 M20	20	53	M20x2.5	27.0	34	13.0	16	77	31	103.5	SW30	16°
EBRM-25	EBLM-25	25	64	M24x2.0	34.0	41	17.0	20	94	38	126.5	SW36	16°
EBRM-30	EBLM-30	30	73	M30x2.0	41.0	48	19.0	22	110	47	146.5	SW41	13°

Available for delivery

► Tolerance Table, Page 1.14

igubal® Rod End Bearings
EBRM / EBLM

PDF: www.igus.com/pdf/igubal.asp
Specs/CAD/RFQ: www.igus.com/igubal.asp
RoHS info: www.igus.com/RoHS.asp

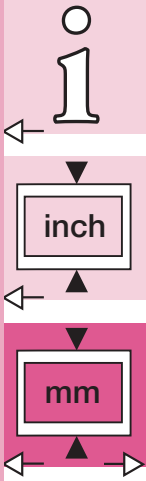

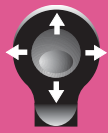

igubal® Rod End Bearing - mm - EARM HT / EALM HT

The EARMHT / EALM HT version is for those applications with higher temperature requirements

EARM HT / EALM HT

igubal® Rod End Bearings

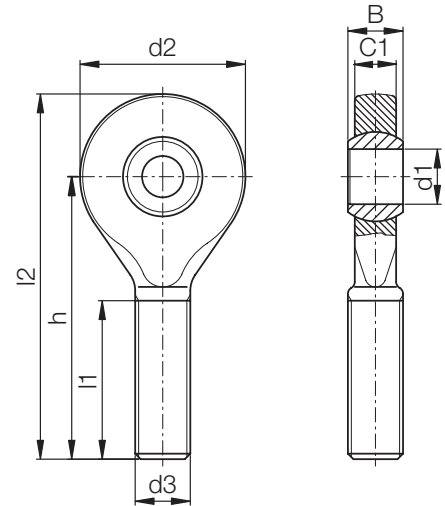

Special properties

- For temperatures up to 392 °F
- Maintenance-free, self-lubricating
- High strength under impact loads
- Very high tensile strength for varying loads
- Compensation for alignment errors
- Compensation for edge loads
- Resistant to dirt, dust and lint
- Resistant to chemicals
- Underwater use
- High vibration dampening capacity
- Suitable for rotating, oscillating and linear movements
- Lightweight
- Dimensional series K according to standard DIN ISO 12240

Telephone 1-888-803-1895
Fax 1-401-438-7680

Dimensions (mm)

Part Number		d1 E10	d2	d3	C1	B	h1	l1	l2	Max. pivot angle
R.-hand thread	L.-hand thread									
EARM-06 HT	EALM-06 HT	6	21	M06	4.4	6	36	20	46.5	27°
EARM-08 HT	EALM-08 HT	8	24	M08	6.0	8	41	24	53.0	24°
EARM-10 HT	EALM-10 HT	10	29	M10	7.0	9	47.5	27	62.0	24°
EARM-12 HT	EALM-12 HT	12	34	M12	8.0	10	54	29	71.0	21°

Available from stock

Internet: <http://www.igus.com>
E-Mail: sales@igus.com
QuickSpec: www.igus.com/qs/igubal.asp

igubal® Rod End Bearing - mm - EBRM HT / EBLM HT

The EBRMHT / EBLM HT version is for those applications with higher temperature requirements

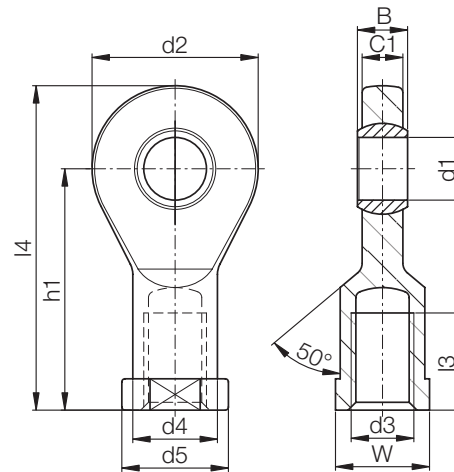
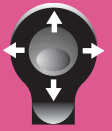

Special properties

- For temperatures up to 392 °F
- Maintenance-free, self-lubricating
- High strength under impact loads
- Very high tensile strength for varying loads
- Compensation for alignment errors
- Compensation for edge loads
- Resistant to dirt, dust and lint
- Resistant to chemicals
- Underwater use
- High vibration dampening capacity
- Suitable for rotating, oscillating and linear movements
- Lightweight
- Dimensional series K according to standard DIN ISO 12240

Dimensions (mm)

Part Number		d1 E10	d2	d3	d4	d5	C1	B	h1	l3	l4	W	Max. pivot angle
R.-hand thread	L.-hand thread												
EBRM-06 HT	EBLM-06 HT	6	21	M06	11.0	13	4.4	6	30	12	40.5	SW11	27°
EBRM-08 HT	EBLM-08 HT	8	24	M08	13.0	16	6.0	8	36	16	48.0	SW14	24°
EBRM-10 HT	EBLM-10 HT	10	29	M10	15.0	19	7.0	9	43	18	57.5	SW17	24°
EBRM-12 HT	EBLM-12 HT	12	34	M12	18.0	22	8.0	10	50	20	67.0	SW19	21°

Available from stock

igubal® Rod End Bearings
EARM HT /EALM HT

PDF: www.igus.com/pdf/igubal.asp
Specs/CAD/RFG: www.igus.com/igubal.asp
RoHS info: www.igus.com/RoHS.asp

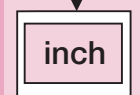



igubal® Adjusting Bolt - mm - PKRM / PKLM

PKRM / PKLM

igubal® Adjusting Bolt



The most significant properties:

- lightweight
- universal resistance to corrosion
- combined with rod end bearings of the dimensional series K
- high strength under impact loads
- vibration dampening
- easy to install
- available in left and right threads

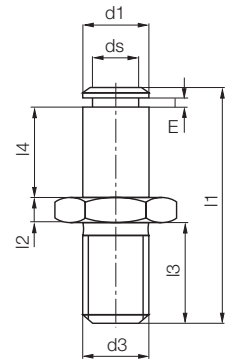
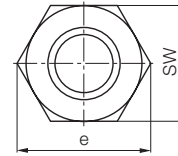

Solid plastic hex bolts with pin serve as an accessory to the rod end bearings of the dimensional series K.

Like all "black" components of the igubal® bearing components, the igubal® adjusting hex bolts consist of the highly shock-resistant, long-fiber reinforced plastic igumid G.

Load Data and Dimensions (mm)

Right-Thread	Left Thread	Max. Static Radial Load Short-term (lbs)	Max. Static Axial Tensile-Strength Short-term (lbs)	d1 (mm) h11	d3 Connection-Thread	SW Width-Across Flats	I1 Total-Length (mm)	I4 Length Adjusting Bolt (mm)	I3 Thread-Length (mm)
PKRM-05	PKLM-05	45	22	5	M05	SW 8	25.0	8.5	11.3
PKRM-06	PKLM-06	56	33	6	M06	SW 10	28.0	9.5	12.8
PKRM-08	PKLM-08	90	56	8	M08	SW 13	32.0	12.5	12.5
PKRM-10	PKLM-10	135	112	10	M10	SW 16	37.5	14.5	14.5
PKRM-12	PKLM-12	202	157	12	M12	SW 18	42.0	16.5	15.5
PKRM-14	PKLM-14	247	179	14	M14	SW 21	47.0	19.5	15.5
PKRM-16	PKLM-16	314	202	16	M16	SW 24	52.0	22.0	16.5
PKRM-18	PKLM-18	382	179	18	M18 x 1.5	SW 27	59.0	24.0	20.5
PKRM-20	PKLM-20	494	112	20	M20 x 1.5	SW 30	67.0	26.0	25.0

Available for delivery

Imperial sizes available. Minimum quantities may be required.

► Tolerance Table, Page 1.14

Telephone 1-888-803-1895

Fax 1-401-438-7680

Internet: <http://www.igus.com>

E-Mail: sales@igus.com

QuickSpec: www.igus.com/qs/igubal.asp

igubal® WGRM

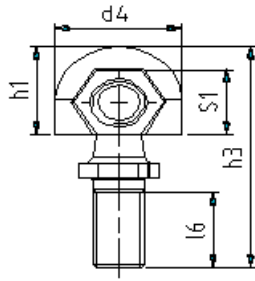

- Connection for rotating and oscillating movement
- Lightweight and robust
- Easy and fast mounting
- Vibration dampening
- Resistant to dirt and dust

Dimensions (mm)

Part number	d1	d2	d4	l1	l2	l5	l6	h3	a	b	e	max. pivot angle
	+0.1 -0.1		+0.5 -0.5	+0.2 -0.2	+0.3 -0.3		min.	+0.5 -0.5	+0.3 -0.3	+0.5 -0.5	+0.5 -0.5	
WGRM-05	8.0	M5	12.8	9.0	10.2	14.0	8.2	25.6	22.0	28.4	11.0	25°
WGRM-06	10.0	M6	14.8	11.0	12.5	16.0	10.5	30.9	25.0	32.4	13.0	25°
WGRM-08	13.0	M8	19.3	13.0	16.5	18.0	13.5	38.8	30.0	39.7	16.0	25°
WGRM-10	16.0	M10	24.0	16.0	20.0	20.0	16.0	47.0	35.0	47.0	18.0	25°

Load data

Part number	max. axial tensile force (lbs) (ball stud axis)	max. axial compressive force (lbs) (ball stud axis)	max. axial tensile force (lbs) (housing axis)	identical experiment (lbs) (metal ball stud)
WGRM-05	6.7	45.0	22.5	134.9
WGRM-06	7.9	67.4	31.5	179.8
WGRM-08	56.2	112.4	45.0	337.2
WGRM-10	112.4	202.3	89.9	427.1

*MS=metal ball stud

igubal® AGRM



- For all mechanical combinations
- Very easy assembling by hand
- Proportion from cohesion to assembling force ca. 10:1
- Maintenance free and predictable

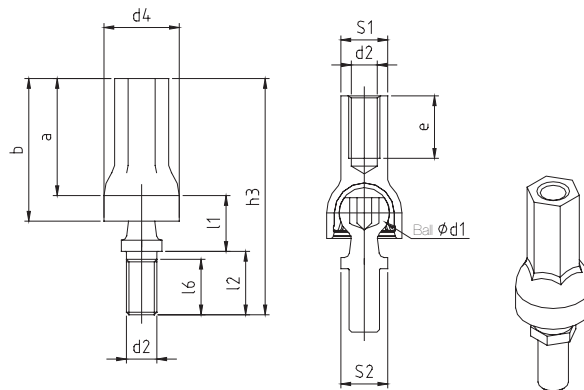

Dimensions (mm)

Part No.	d1	d2	d4	l1	l2	l6	h3	S1	S2	a	b	e	pivot angle	
	+0.1 -0.1		+0.5 -0.5	+0.2 -0.2	+0.3 -0.3	min.	+0.5 -0.5			+0.3 -0.3	+0.5 -0.5	min.	Recom.	max.
AGRM-08	13.0	M8	19.3	13.0	16.5	13.5	59.0	SW12	SW11	29.5	36.5	16.0	18°	25°

Load data

Part No.	max. static axial tensile strength		max. static axial compressive strength		max. assembling force (lbs)	measured min. cohesion (lbs)	factor	max. cyclic axial tensile/compr. force (lbs)	max. torque	
	short term (lbs)	long term (lbs)	short term (lbs)	long term (lbs)					housing (ft lbs)	ball stud (ft lbs)
AGRM-08	56.2	28.1	224.8	112.4	24.7	157.4	6.5	16.9	3.7	1.5

igubal® Rod End Bearings
WGRM/AGRM

PDF: www.igus.com/pdf/igubal.asp
Specs/CAD/RFQ: www.igus.com/igubal.asp
RoHS info: www.igus.com/RoHS.asp

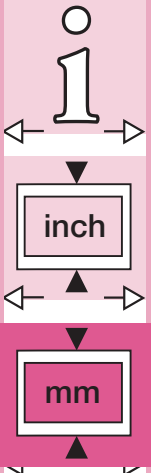

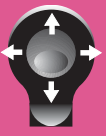

igubal® Spherical Bearing Analysis

Please photocopy, fill out and fax to 401-438-7680

igubal® Rod End Bearings

Telephone 1-888-803-1895
Fax 1-401-438-7680

Internet: <http://www.igus.com>
E-Mail: sales@igus.com
QuickSpec: www.igus.com/qs/igubal.asp

Date:	Telephone: 1-888-803-1895 Fax: 1-401-438-7680
From:	To: igus®, inc. Technical Sales iglide® Plastic Bearings P.O. Box 14349 East Providence, RI 02914
Telephone:	
Fax:	

Please enter as much data as possible. If you prefer other measuring units, cross out the given unit and write your next to it. Most applications questions can be answered with just a partial amount of data.

Please call us if you have any questions (Tel: 1-888-803-1895)

- Rod End Bearing Type A (outer thread)
- Rod End Bearing Type B (Inner thread)
- Pillow Block
- Spherical Bearing
- Flange Bearing 2-Bolt
 4-Bolt
- Clevis Joint with pin and clip
 spring loaded hasp pin

- Dimensional Series: E
 K

- Threading: Standard thread
 Fine thread

Speed (fpm; 1/min):

- Type of movements:
 rotating _____
- pivoting by _____
_____degrees
- linear _____

- Lubrication: dry
 Oil/grease
 Water

Shaft diameter (mm/inch): _____

Bearing load (lbs): _____

Outside temperature (°F): _____

Shaft material (e.g. steel, VA, plastic):

Average roughness Ra: _____

Target service life (hrs.): _____

Present bearing type:

Surrounding media (e.g. acids, water, lyes...):

- Which problem can iglide® solve for you?
- dry running
 - corrosion
 - vibration-dampening
 - cost reduction
 - chemicals
 - dirt
 - dust
 - weight

Other load characteristics:

Drawing:

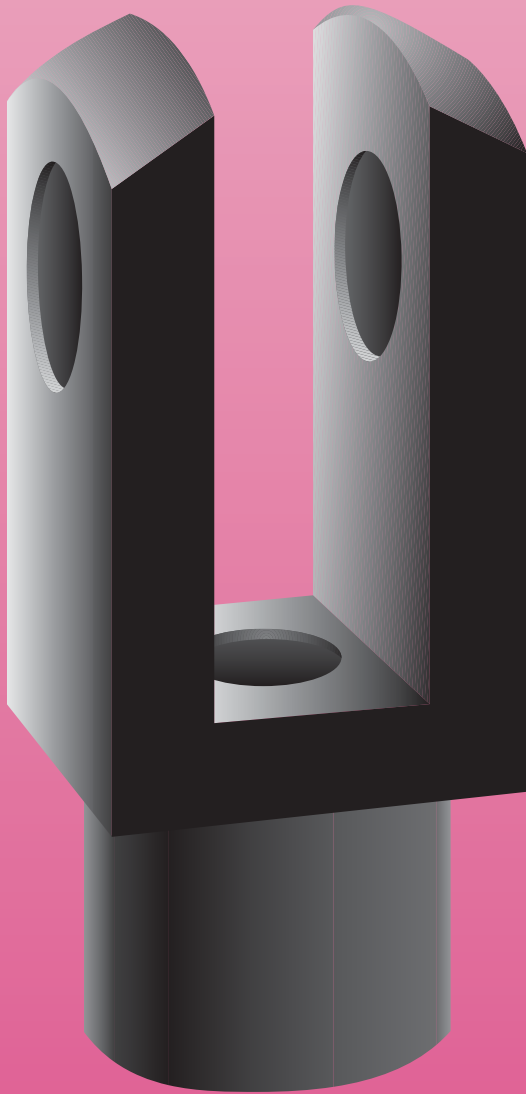

igubal[®] Clevis Joint

- High tensile strength
- Vibration dampening
- Noise dampening
- Lightweight
- Can be used in combination with Rod End Bearings of the dimensional Series E





The most significant properties:

- lightweight
- universal corrosion resistance
- high tensile strength
- can be used in combination with rod end bearings of the dimensional series E
- vibration dampening
- noise dampening
- available in left and right threads

igubal[®] clevis joints are all made of igumid G according to DIN 71752, which can be used in combination with the rod end bearings of the dimensional series E. Available components are clevis joint, clevis pin and clip or as an alternative, spring-loaded pin.

Part Selections

All of the components listed below are also available individually



Clevis joint with clevis pin and clip
GER(L)MK-



Clevis joint with spring-loaded pin
GER(L)MF-



Clevis joint with clevis pin and clip and rod end bearing
GER(L)MKE-



Clevis joint with spring loaded pin and rod end bearing
GER(L)MFE-

Structure of the part numbers for igubal[®] Clevis Joints

The part numbers of igubal clevis joints are designed according to the following system:

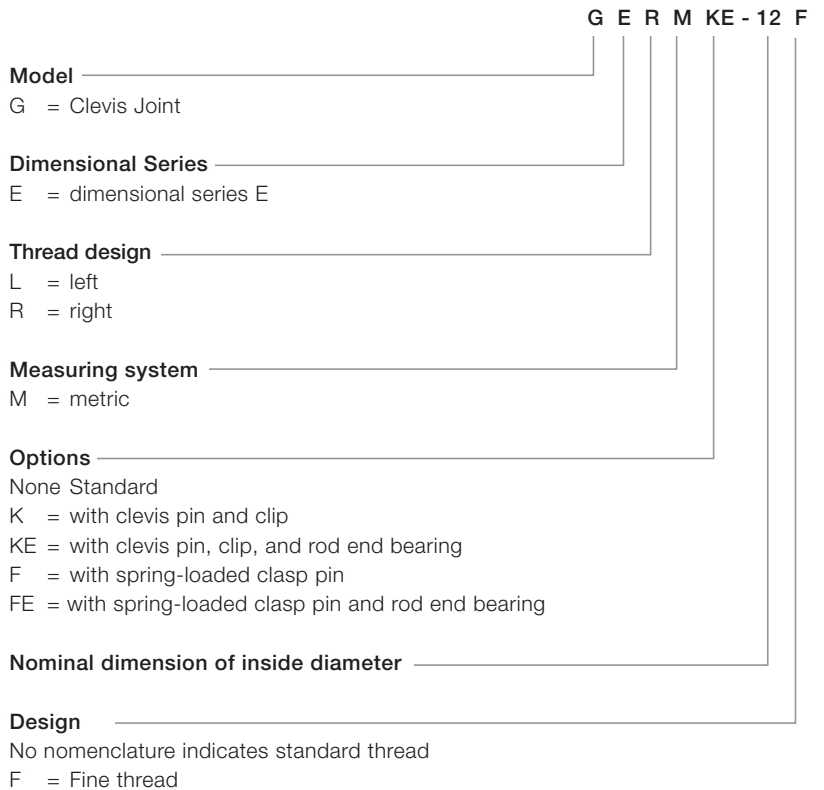

The example shows a complete clevis joint assembly of the dimensional series E with inner right threading in metric dimensions. The inner diameter of the spherical ball is 12mm. The thread bore has a metric fine threading (M12 x 1.25).

igubal® Clevis Joint - mm - GERI / GELI GERIK/GELIK



- lightweight
- universal corrosion resistance
- high tensile strength
- Can be used in combination with rod end bearings of the dimensional series E
- vibration dampening
- noise dampening
- available in left and right thread

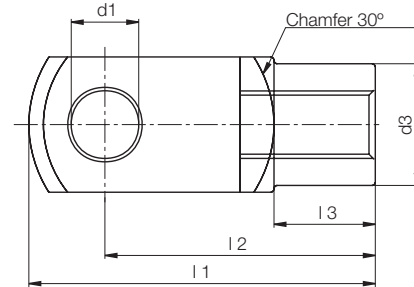
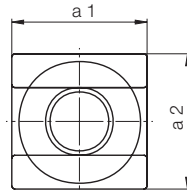
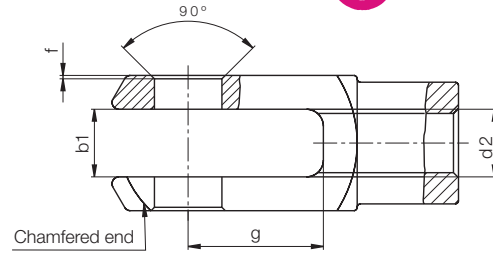

Dimensions (inch)

Right (Left) Thread	d1 H9	g h11	a1	a2 +0.3 -0.16	b1 B13	d2 Thread- Tolerance 6H	d3 +0.3 -0.3	f +0.3 -0.3	l1 +0.5 -0.5	l2 +0.3 -0.3	l3 +0.2 -0.2
GER(L)I-03	0.1875	0.394	0.394	0.394	0.197	10-32	0.354	.02	1.024	0.787	0.295
GER(L)I-04	0.2500	0.472	0.472	0.472	0.236	-28	0.394	.02	1.205	0.945	0.354
GER(L)I-05	0.3125	0.630	0.630	0.630	0.315	5/16-24	0.551	.02	1.638	1.260	0.472
GER(L)I-06	0.3750	0.787	0.787	0.787	0.394	3/8-24	0.709	.02	2.020	1.575	0.591
GER(L)I-07	0.4375	0.945	0.945	0.945	0.472	7/16-20	0.787	.02	2.413	1.890	0.709
GER(L)I-08	0.5000	1.102	1.063	1.063	0.551	1/2-20	0.945	.02	2.807	2.205	0.886

Load Data

Right (Left) Thread	Max. Static Axial Tensile Strength GERM		Right (Left) Thread	Max. Static Axial Tensile Strength GERMK	
	Short-term (lbs)	Long-term (lbs)		Short-term (lbs)	Long-term (lbs)
GER(L)I-03	225	112	GER(L)IK-03	202	90
GER(L)I-04	270	135	GER(L)IK-04	202	101
GER(L)I-05	607	303	GER(L)IK-05	472	236
GER(L)I-06	1056	528	GER(L)IK-06	674	404
GER(L)I-07	1281	640	GER(L)IK-07	787	393
GER(L)I-08	719	360	GER(L)IK-08	629	315

► Tolerance Table, Page 1.14

igubal® Clevis
Joint

GERI / GELI

PDF: www.igus.com/pdf/igubal.asp
Specs/CAD/RFQ: www.igus.com/igubal.asp
RoHS info: www.igus.com/RoHS.asp



inch

mm



igubal® Clevis Joint - mm - GERM/GELM GERMK/GELMK



- lightweight
- universal corrosion resistance
- high tensile strength
- Can be used in combination with rod end bearings of the dimensional series E
- vibration dampening
- noise dampening
- available in left and right thread

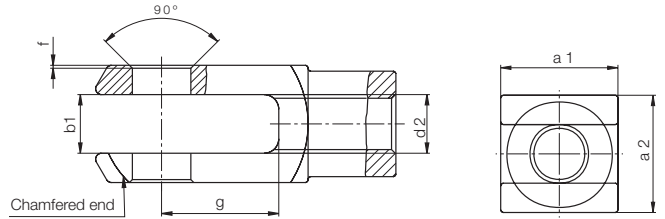
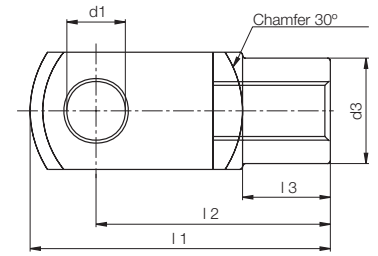

Load Data

Right (Left) Thread	Max. Static Axial Tensile Strength GERM		Right (Left) Thread	Max. Static Axial Tensile Strength GERMK	
	Short-term (lbs)	Long-term (lbs)		Short-term (lbs)	Long-term (lbs)
GER(L)M-04	179	90	GER(L)MK-04	135	67
GER(L)M-05 DIN M4	225	112	GER(L)MK-05 DIN M4	202	90
GER(L)M-05 DIN M5	225	112	GER(L)MK-05 DIN M5	180	90
GER(L)M-05	270	135	GER(L)MK-05	202	101
GER(L)M-06	314	157	GER(L)MK-06	292	146
GER(L)M-08	607	303	GER(L)MK-08	472	236
GER(L)M-10	1056	528	GER(L)MK-10	674	404
GER(L)M-10 F	1056	528	GER(L)MK-10 F	674	404
GER(L)M-12	1281	640	GER(L)MK-12	787	393
GER(L)M-12 F	1281	640	GER(L)MK-12 F	787	393
GER(L)M-14	1483	741	GER(L)MK-14	1371	685
GER(L)M-15	719	360	GER(L)MK-15	629	315
GER(L)M-16	1686	843	GER(L)MK-16	1573	786
GER(L)M-16 F	1686	843	GER(L)MK-16 F	1573	786
GER(L)M-20	2136	1068	GER(L)MK-20	2023	1012
GER(L)M-20	2136	1068	GER(L)MK-20	2023	1012

Dimensions (mm)

Right (Left) Thread	d1	g	a1	a2	b1	d2	d3	f	l1	l2	l3
	H9	h11		+0.3 -0.16	B13	Thread- Tolerance 6H	+0.3 -0.3	+0.3 -0.3	+0.5 -0.5	+0.3 -0.3	+0.2 -0.
GER(L)M-04	4	8	8	8	4	M4	8.0	0.5	21.0	20	7.5
GER(L)M-05 DIN M4	5	10	10	10	5	M04	9	0.5	25.5	20	7.5
GER(L)M-05 DIN M5	5	10	10	10	5	M04	9	0.5	25.5	20	7.5
GER(L)M-05	5	12	12	12	6	M05	10.0	0.5	30.6	24.0	9.0
GER(L)M-06	6	12	12	12	6	M06	10.0	0.5	30.6	24.0	9.0
GER(L)M-08	8	16	16	16	8	M08	14.0	0.5	41.6	32.0	12.0
GER(L)M-10	10	20	20	20	10	M10	18.0	0.5	51.3	40.0	15.0
GER(L)M-10 F	10	20	20	20	10	M10x1.25	18.0	0.5	51.3	40.0	15.0
GER(L)M-12	12	24	24	24	12	M12	20.0	0.5	61.3	48.0	18.0
GER(L)M-12 F	12	24	24	24	12	M12x1.25	20.0	0.5	61.3	48.0	18.0
GER(L)M-14	14	28	27	27	14	M14	24.0	0.5	71.3	56.0	22.5
GER(L)M-15	15	28	27	27	14	M14	24.0	0.5	71.3	56.0	22.5
GER(L)M-16	16	32	32	32	16	M16	26.0	1.0	81.9	64.0	24.0
GER(L)M-16 F	16	32	32	32	16	M16x1.5	26.0	1.0	81.9	64.0	24.0
GER(L)M-20	20	40	40	40	20	M20x1.5	34.0	1.0	105.0	80.0	30.0
GER(L)M-20	20	40	40	40	20	M20x2.5	34.0	1.0	105.0	80.0	30.0

GERMKE / GELMKE

igubal® Clevis Joint

Telephone 1-888-803-1895

Fax 1-401-438-7680

Internet: <http://www.igus.com>

E-Mail: sales@igus.com

QuickSpec: www.igus.com/qs/igubal.asp



Load Data

igubal® - Clevis Joints dimensional series E - complete joint assembly GERMKE/GELMKE, consisting of clevis joint GERM/GELM, clevis, pin, clip, and rod end bearing of the series EBRM/EBLM

Right-Thread	Left-Thread	Max. Static Axial Tensile Strength GERM Short-term (lbs)	Max. Static Axial Tensile Strength GERM Long-term (lbs)
GERMKE-05 M5	GELMKE-05 M5	202	101
GERMKE-06	GELMKE-06	292	146
GERMKE-08	GELMKE-08	449	224
GERMKE-10	GELMKE-10	517	258
GERMKE-10 F	GELMKE-10 F	517	258
GERMKE-12	GELMKE-12	741	370
GERMKE-12 F	GELMKE-12 F	741	370

igubal® Spring Loaded Pins - mm - GEFM



- single-piece construction
- easy to install
- maintenance-free
- can be used in combination with rod end bearings of the dimensional series E
- high stability

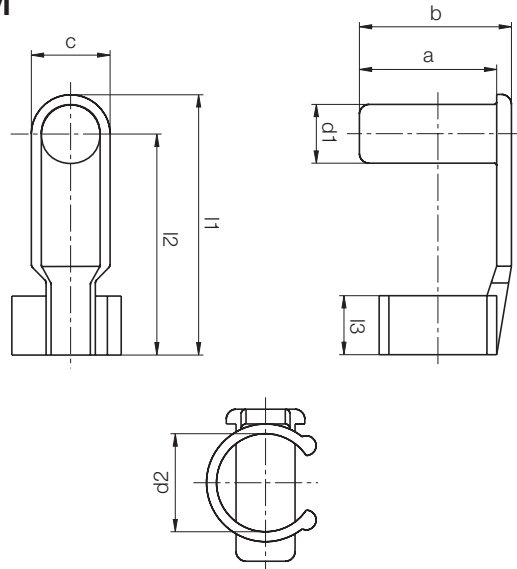

Dimensions (mm)

Part Number	d1 h11	d2	a	b	c	l1 ±0.5	l2	l3
GEFM-04	4	8	9.5	10.5	8	19	15	4.5
GEFM-05	5	10	14	15.5	8	27	23	6.5
GEFM-06	6	10	14	15.5	8	27	23	6.5
GEFM-08	8	14	19	21.0	11	35.5	30	8.0
GEFM-10	10	18	23	25.5	14	45	38	10.0
GEFM-12	12	20	28	31.0	16	53	45	12.0
GEFM-16	16	26	36	40.0	22	73	62	16.0

igubal® Clevis Joint
GER(L)MKE
GEFM

PDF: www.igus.com/pdf/igubal.asp
Specs/CAD/RFQ: www.igus.com/igubal.asp
RoHS info: www.igus.com/RoHS.asp

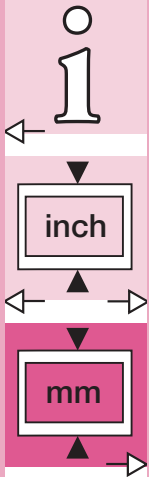



igubal® Clevis Pin - inch/mm - GBI/GBM

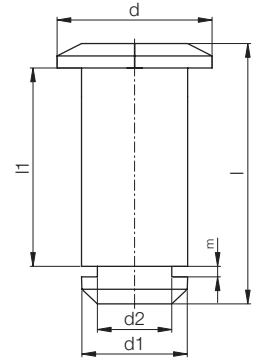

Dimensions (mm)

Part Number Pin	d1	d2	d	l	l1	m	Clip
GBI-03	.1875	.1260	.3125	.55	.3975	.0472	GSR-04
GBI-04	.2500	.1969	.3750	.65	.4764	.0512	GSR-08
GBI-05	.3125	.1969	.4375	.85	.6339	.0512	GSR-08
GBI-06	.3750	.2756	.5000	1.05	.7953	.0591	GSR-10
GBI-07	.4375	.3543	.6250	1.25	.9528	.0669	GSR-12
GBI-08	.5000	.3543	.7500	1.40	1.0709	.0669	GSR-12

Dimensions (inch)

Part Number Pin	d1	d2	d	l	l1	m	CLIP
GBM-04	4	3.2	7	12.50	8	1.05	GSR-04
GBM-05	5	4.0	8	16.50	12	1.15	GSR-06
GBM-05 DIN	5	4.0	8	14.50	10	1.15	GSR-06
GBM-06	6	4.0	9	16.50	12	1.15	GSR-06
GBM-08	8	5.0	12	21.50	16	1.15	GSR-08
GBM-10	10	7.0	15	27.00	20	1.35	GSR-10
GBM-12	12	9.0	18	31.50	24	1.50	GSR-12
GBM-14	14	12.0	22	36.00	27	1.70	GSR-16
GBM-15	15	12.0	23	36.00	27	1.70	GSR-16
GBM-16	16	12.0	24	42.00	32	1.70	GSR-16
GBM-17	17	12.0	25	42.00	32	1.70	GSR-16
GBM-20	20	15.0	30	51.00	40	2.00	GSR-20

GBI / GBM

igubal® Clevis Pin/Clip

Telephone 1-888-803-1895

Fax 1-401-438-7680

Internet: <http://www.igus.com>

E-Mail: sales@igus.com

QuickSpec: www.igus.com/qs/igubal.asp

igubal® Clevis Clip - mm - GSR

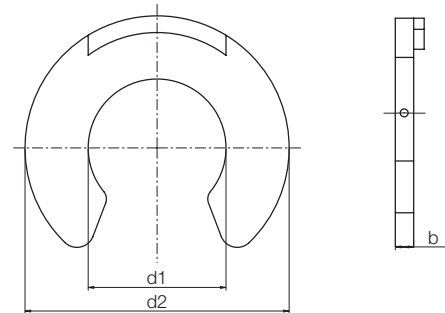

Dimensions (mm)

Part Number Pin	d1	d2	b
GSR-04	3.20	7.0	1.00
GSR-06	4.00	9.0	1.10
GSR-08	5.00	11.0	1.10
GSR-10	7.00	14.0	1.30
GSR-12	9.00	18.5	1.40
GSR-16	12.00	23.0	1.60
GSR-20	15.00	28.0	1.90

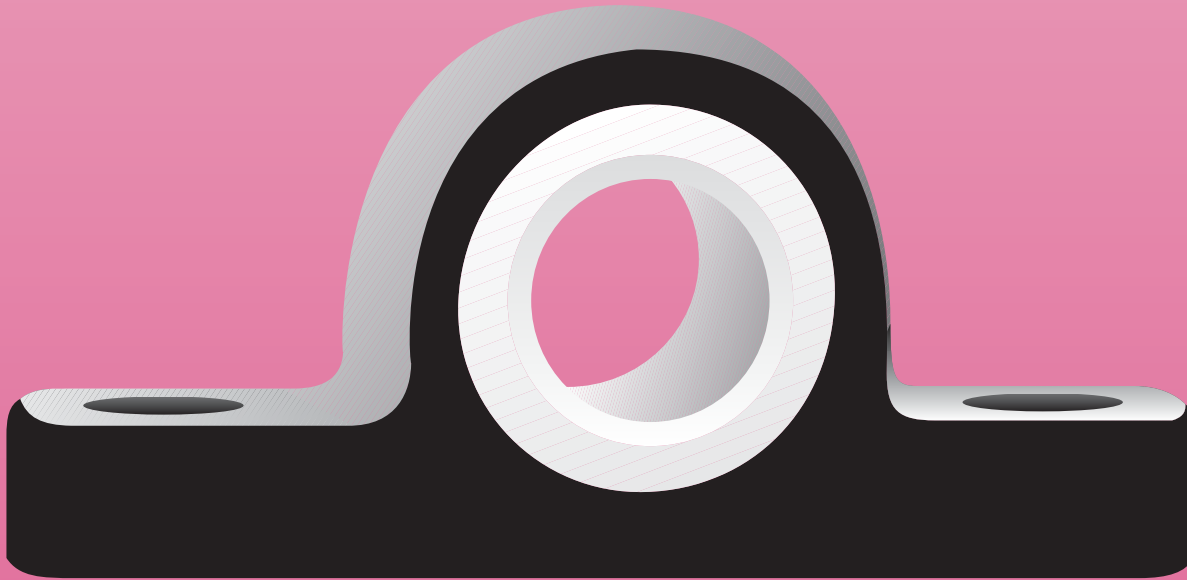

igubal[®] Pillow Block Bearing

- Maintenance-free, self-lubricating
- High strength under impact loads
- High tensile strength
- Compensation for alignment errors
- Chemical resistant
- Lightweight





igubal® Pillow Block Bearing

igubal® Pillow Block Bearings are bearing elements that are especially easy to install, able to compensate for alignment errors and prevent edge loads.



Product Range

igubal® pillow block bearings can be obtained in the standard dimensions for IDs of .1900" to 1.00" and for metric sizes of 5mm to 50 mm.

Areas of Application

The ability to pivot allows igubal® pillow block bearings to compensate for misalignment and possible shaft deflection. Applications in which these effects cannot be prevented are suited for igubal® pillow block bearings.

Tolerances

Maintenance-free igubal® pillow block bearings are designed with a tolerance in the inner diameter according to E10. The shaft should have a tolerance of H6 and h9. The recommended tolerances allow for changes in the bearing due to temperature.

► Tolerance Table, Page 1.14

Mounting

igubal® pillow block bearings are designed for mounting with 2 bolts. Precision mounting of the bearing is not necessary, since the spherical ball compensates for alignment errors.

Structure of Part Numbers for igubal® Pillow Block Bearings

The part numbers of igubal® pillow block bearings are designed according to the following system:

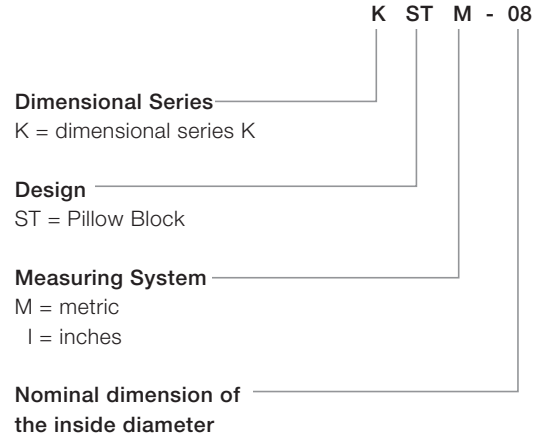

The example shows a pillow block bearing of the dimensional series K with metric dimensions. The spherical ball has an inner diameter of 8 mm.

igubal® Pillow Block

Telephone 1-888-803-1895
Fax 1-401-438-7680

Telephone 1-888-803-1895
Fax 1-401-438-7680

Internet: <http://www.igus.com>
E-Mail: sales@igus.com
QuickSpec: www.igus.com/qs/igubal.asp



igubal® Pillow
Block



igubal® pillow block bearings in conveyor systems for the food industry (see pictures at the right for details)



igubal® pillow block bearings in a conveyor system



igubal® pillow block bearings in a conveyor system



Sideboard with integrated TV lifting mechanism (see picture at the right for details)



igubal® pillow block bearings with DryLin® T linear guide in the lifting mechanism

PDF: www.igus.com/pdf/igubal.asp
 Specs/CAD/RFQ: www.igus.com/igubal.asp
 RoHS info: www.igus.com/RoHS.asp

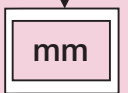
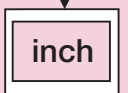



igubal® Pillow Block Bearing - inch - KSTI

KSTI

igubal® Pillow Block



Special Properties

- Maintenance-free, self-lubricating
- High strength under impact loads
- High tensile strength for varying loads
- Compensation for alignment errors
- Compensation for edge loads
- Corrosion-resistant
- Chemical-resistant
- High vibration dampening capacity
- Suitable for rotating, oscillating and axial movements
- Lightweight

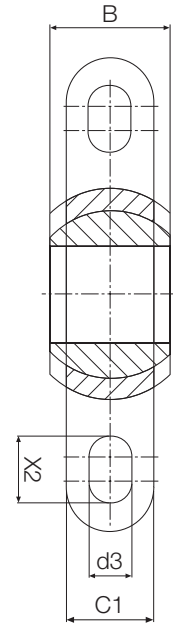
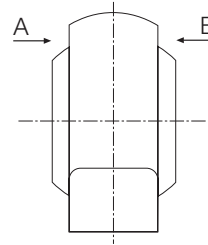
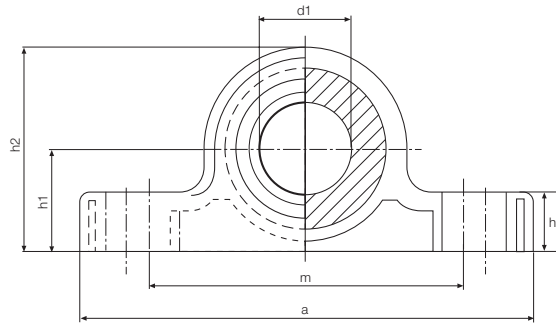

Telephone 1-888-803-1895
Fax 1-401-438-7680

Telephone 1-888-803-1895
Fax 1-401-438-7680

Load Data

Part Number	Maximum Static Tensile Strength Short-term	Maximum Static Tensile Strength Long-term	Maximum Static Axial Strength	Maximum Torque for Longitudinal holes
	(lbs)	(lbs)	(lbs)	(ft lbs)
KSTI-03	124	62	79	0.4
KSTI-04	135	67	90	0.4
KSTI-05	180	90	112	0.6
KSTI-06	225	112	135	1.0
KSTI-07	247	124	157	1.8
KSTI-08	270	135	169	1.8
KSTI-10	472	236	202	1.8
KSTI-12	697	348	360	3.3
KSTI-16	1214	607	495	7.7

Dimensions (inch)

Part Number	a	d1 E10	B	C1	h1	h2	h3	m	d3	X2	Max. Angle of Pivot
KSTI-03	1.4000	.1900	.312	.234	.290	.566	.165	1.000	.137	.200	25°
KSTI-04	1.7500	.2500	.375	.250	.390	.705	.205	1.250	.137	.250	25°
KSTI-05	1.9500	.3125	.437	.312	.430	.824	.236	1.350	.150	.280	25°
KSTI-06	2.4000	.3750	.500	.359	.550	1.022	.376	1.800	.180	.300	22°
KSTI-07	2.5000	.4375	.562	.406	.570	1.082	.315	1.850	.205	.330	22°
KSTI-08	2.8000	.5000	.625	.453	.600	1.191	.354	2.000	.205	.380	22°
KSTI-10	3.3500	.6250	.750	.484	.700	1.409	.413	2.300	.205	.470	22°
KSTI-12	3.7500	.7500	.875	.593	.860	1.687	.472	2.700	.270	.530	22°
KSTI-16	5.0000	1.0000	1.375	1.005	1.100	2.163	.630	3.500	.520	.680	20°

Available from stock

► Tolerance Table, Page 1.14

Internet: <http://www.igus.com>
E-Mail: sales@igus.com
QuickSpec: www.igus.com/qs/igubal.asp

igubal® Pillow Block Bearing - mm - KSTM



Special Properties

- Maintenance-free, self-lubricating
- High strength under impact loads
- High tensile strength for varying loads
- Compensation for alignment errors
- Compensation for edge loads
- Corrosion-resistant
- Chemical-resistant
- High vibration dampening capacity
- Suitable for rotating, oscillating and axial movements
- Lightweight

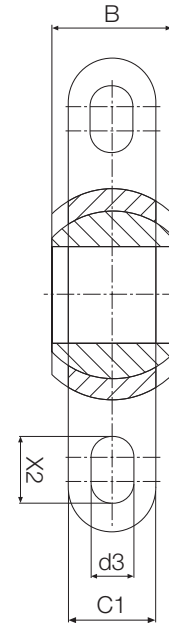
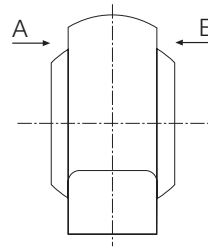
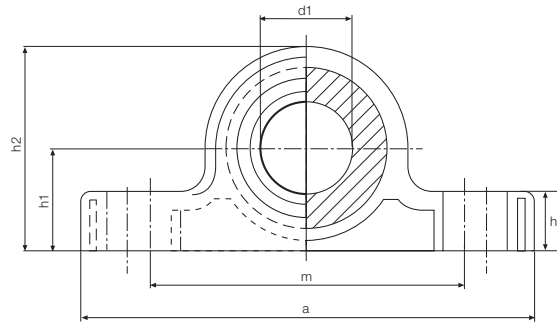

Load Data

Part Number	Maximum Static Tensile Strength Short-term	Maximum Static Tensile Strength Long-term	Maximum Static Axial Compressive Strength	Maximum Torque for Longitudinal holes
	(lbs)	(lbs)	(ft lbs)	
KSTM-05	157	78	90	0.4
KSTM-06	247	123	90	1.0
KSTM-08	292	146	180	1.0
KSTM-10	337	168	247	1.8
KSTM-12	494	247	259	1.8
KSTM-14	539	269	270	3.3
KSTM-16	674	337	405	3.3
KSTM-18	786	393	427	7.7
KSTM-20	1056	528	562	7.7
KSTM-22	1371	685	607	7.7
KSTM-25	1483	741	719	7.7
KSTM-30	1820	910	843	15.9

Dimensions (mm)

Part Number	a	d1 E10	B	C1	h1	h2	h3	m	d3	X2	Max. Angle of Pivot
KSTM-05	34	5	8	6.0	7	14	4	25	3.3	5	30°
KSTM-06	43	6	9	7.0	10	18	5.5	33	4.5	6	29°
KSTM-08	47	8	12	9.0	10	20	6	33	4.5	7	25°
KSTM-10	62	10	14	10.5	14	26	7.5	46	5.5	8	25°
KSTM-12	65	12	16	12.0	14	28	8.5	46	5.5	9	25°
KSTM-14	82	14	19	13.5	18	34	9.5	60	6.6	11	23°
KSTM-16	86	16	21	15.0	18	36	10.5	60	6.6	12	23°
KSTM-18	93	18	23	16.5	22	42	11.5	68	9.0	13	23°
KSTM-20	98	20	25	18.0	22	44	13	68	9.0	14	23°
KSTM-22	108	22	28	20.0	24	48	14	74	9.0	16	22°
KSTM-25	124	25	31	22.0	27	54	16	86	9.0	17	22°
KSTM-30	139	30	37	25.0	32	64	17	96	11.0	20	22°

Available from stock

► Tolerance Table, Page 1.14

igubal® Pillow Block

KSTM

PDF: www.igus.com/pdf/igubal.asp
 Specs/CAD/RFQ: www.igus.com/igubal.asp
 RoHS info: www.igus.com/RoHS.asp

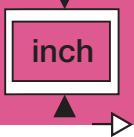
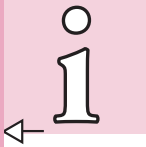



igubal® Pedestal Bearing - mm - KSTM-GT

Familiar characteristics such as self-adjustment and zero-maintenance are now available with dimensions of 35, 40, 45 and 50 mm.

igubal® Pillow Block



Special Properties

- High rigidity
- High fatigue strength
- Corrosion-proof
- Low weight
- Easy assembly and dismantling
- Maintenance-free spherical cap made of iglide® J

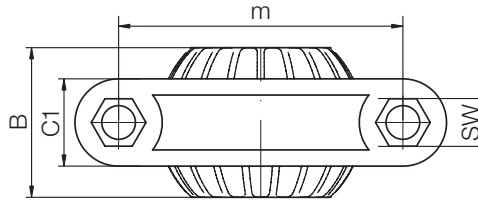
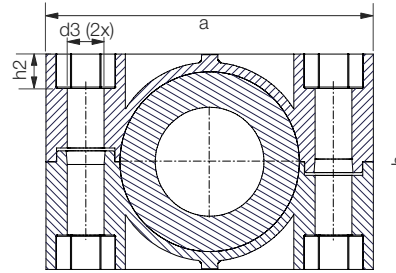
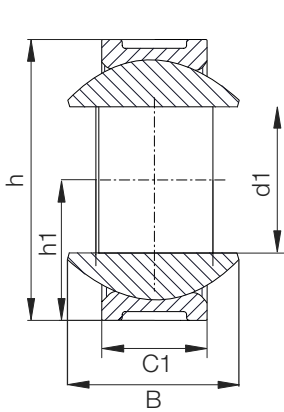
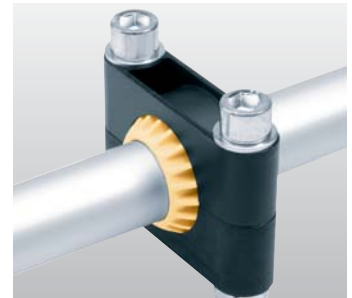

Telephone 1-888-803-1895
Fax 1-401-438-7680

Dimensions (mm)

Part Number	d1 (E10)	d3	h	h1	h2	SW	a	m	C1	B	Max. Pivot Angle
KSTM-GT35*	35.0	13.5	79.0	39.5	12.6	19.0	120.5	91.0	29.5	48.5	24°
KSTM-GT40	40.0	13.5	79.0	39.5	12.6	19.0	120.5	91.0	29.5	48.5	24°
KSTM-GT45*	45.0	13.5	100.0	50.0	12.6	19.0	149.0	114.0	35.0	60.0	24°
KSTM-GT50	50.0	13.5	100.0	50.0	12.6	19.0	149.0	114.0	35.0	60.0	24°

*Diameter given by iglide J reducer

**Spherical balls are also available with split design

Load data

Part Number	Max. radial tensile strength		Max. axial tensile strength		Max. Torque	
	Short term (lbs)	Long term (lbs)	Short term (lbs)	Long term (lbs)	through ball (ft lbs)	fixing holes (ft lbs)
KSTM-GT35*	2473	1236	562	281	14.8	11.1
KSTM-GT40	2473	1236	562	281	14.8	11.1
KSTM-GT45*	3372	1686	674	337	14.8	14.8
KSTM-GT50	3372	1686	674	337	14.8	14.8

Internet: <http://www.igus.com>
E-Mail: sales@igus.com
QuickSpec: www.igus.com/qs/igubal.asp



Special Properties

- High radial loads
- Can be used in liquid media
- Space-saving design
- Easy to install
- Predictable lifetime
- Maintenance-free, self-lubricating

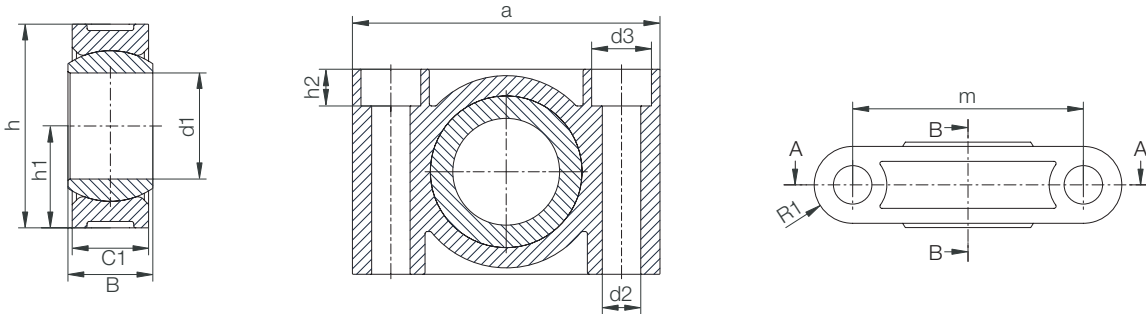

Load Data

Part Number	Max. radial tensile strength		Max. radial compressive strength		Maximum axial strength		Maximum torque in the assembly (ft lbs)
	Short term (lbs)	Long term (lbs)	Short term (lbs)	Long term (lbs)	Short term (lbs)	Long term (lbs)	
	ESTM-08	562	281	967	483	135	
ESTM-10	764	382	1191	596	157	79	1.84
ESTM-12	1012	506	1461	731	169	84	1.84
ESTM-16	1506	753	1911	955	247	124	3.32
ESTM-20	1911	955	2473	1293	315	157	3.32
ESTM-25	3035	1517	4159	2079	517	259	7.75
ESTM-30*	2248	1124	3709	1855	562	281	7.75

* Due to the different manufacturing method, the load values of the ESTM-30 are lower than ESTM-25

Dimensions (mm)

Part Number	d1	d2	d3	h	h1	h2	a	m	C1	B	R1	Max. Pivot Angle
ESTM-08	8.0	4.5	-	19	9.5	-	31.0	22.0	9.0	8.0	4.5	22°
ESTM-10	10.0	5.5	-	22	11	-	36.0	26.0	10.0	9.0	5.0	22°
ESTM-12	12.0	5.5	-	26	13	-	38.0	28.0	10.0	10.0	5.0	22°
ESTM-16	16.0	6.6	10.6	34.0	17.0	6.4	50.0	37.0	13.0	13.0	6.5	22°
ESTM-20	20.0	9.0	14.0	40.0	20.0	8.6	62.0	46.0	16.0	16.0	8.0	22°
ESTM-25	25.0	9.0	14.0	48.0	24.0	8.6	72.0	54.0	18.0	20.0	9.0	20°
ESTM-30	30.0	11.0	17.0	56.0	28.0	10.6	86.0	64.0	22.0	22.0	11.0	20°

igubal® Pillow Block ESTM

PDF: www.igus.com/pdf/igubal.asp
 Specs/CAD/RFQ: www.igus.com/igubal.asp
 RoHS info: www.igus.com/RoHS.asp

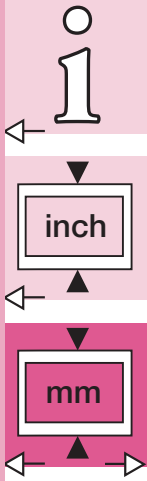



igubal® Pillow Block Bearing - mm - ESTM - SL

ESTM SL

igubal® Pillow Block



Special Properties

- Light weight
- Extremely space saving
- Mounts with cap screws
- Low cost
- Predictable lifetime
- Maintenance- and lubricant-free

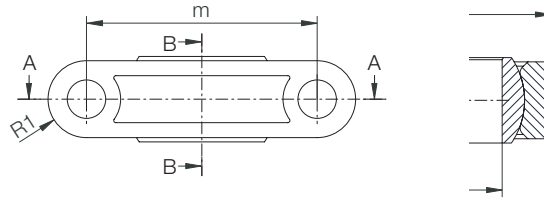
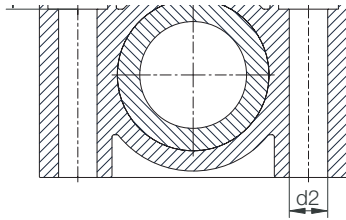

Load Data (mm)

Part Number	Max. radial tensile strength		Max. radial compressive strength		Maximum lateral strength		Maximum axial strength	
	Short term (lbs)	Long term (lbs)	Short term (lbs)	Long term (lbs)	Short term (lbs)	Long term (lbs)	Short term (lbs)	Long term (lbs)
ESTM-05-SL	337	169	315	157	202	101	34	17
ESTM-06-SL	337	169	315	157	202	101	34	17
ESTM-08-SL	360	180	315	157	214	107	22	11
ESTM-10-SL	360	180	315	157	214	107	22	11

Dimensions (mm)

Part Number	d1 (H10)	d2	dk	h	h1	h2	a	m	C1	R1	Max. Pivot Angle
ESTM-05-SL	5.0	2.5	8.9	18.0	10.0	6.5	16.0	10.0	6.0	8.0	17°
ESTM-06-SL	6.0	2.5	8.9	18.0	10.0	6.5	16.0	10.0	6.0	8.0	17°
ESTM-08-SL	8.0	2.5	10.5	19.0	10.0	6.5	18.0	12.0	6.0	9.0	17°
ESTM-10-SL	10.0	2.5	12.4	20.0	10.0	6.5	20.0	14.0	6.0	10.0	17°

Telephone 1-888-803-1895
Fax 1-401-438-7680

Internet: <http://www.igus.com>
E-Mail: sales@igus.com
QuickSpec: www.igus.com/qs/igubal.asp

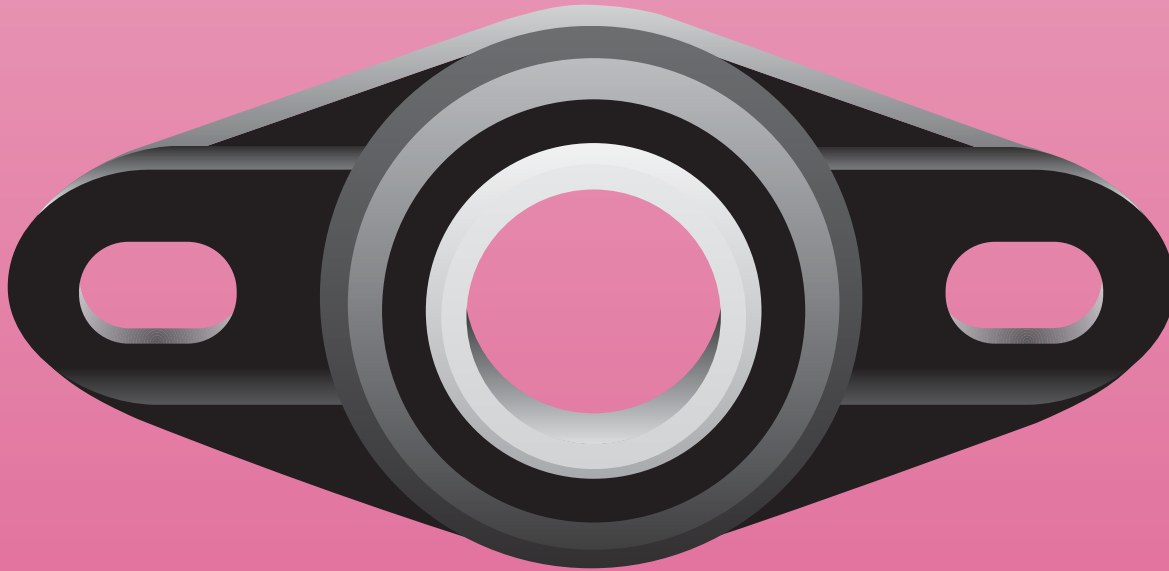

igubal[®] Flange Bearing

- Maintenance-free, Self-lubricating
- High strength under impact loads
- High tensile strength
- Compensation for alignment errors
- Compensation for edge loads
- Resistant to chemicals
- Lightweight





igubal® Flange Bearing

Like all igubal® products, they consist of a housing made of igumid G and a spherical balls made of either iglide® L280 or iglide® R for standard parts or with any iglide® material as a special. igubal flange bearing correspond to the dimensional series E and are offered with two or four mounting holes.



igubal® Flange Bearing

Telephone 1-888-803-1895
Fax 1-401-438-7680

Telephone 1-888-803-1895
Fax 1-401-438-7680

Areas of Application

Since igubal® flange bearings are made for maintenance-free use, they are especially suited for applications in which access to the bearing is limited, in moist or wet environments or clean-room environments. Thus, igubal® flange bearings are also found in electric toothbrushes, awnings, conveyor technology, bakery machines and agriculture.

Installation

igubal® flange bearings are designed for mounting with 2 or 4 bolts, depending on the design. The 2-hole types are provided with elongated holes, which allow a problem-free adjustment. An exact positioning of the bearing housing is not necessary, since the spherical ball compensates for alignment errors.

Product Range

igubal® flange bearings with 2 and 4 mounting holes can be obtained in the standard dimensions with IDs of .190" to 1.00" and metric sizes of 5 to 50 mm. Please ask about additional dimensions.

Maximum permissible tensile strength forces

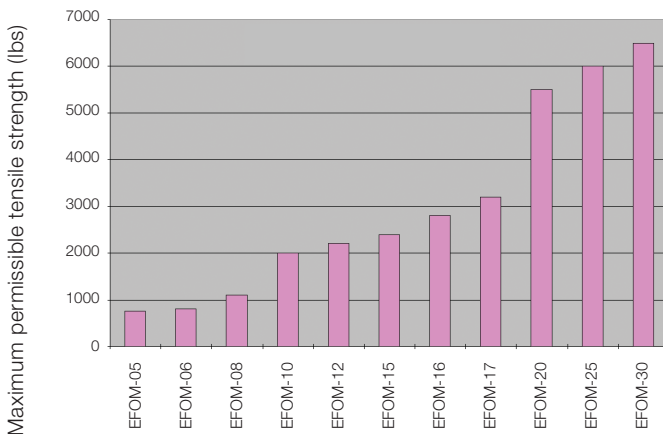

Structure for Part Numbers for igubal® Flange Bearings

The part numbers of igubal® flange bearings are designed according to the following system:

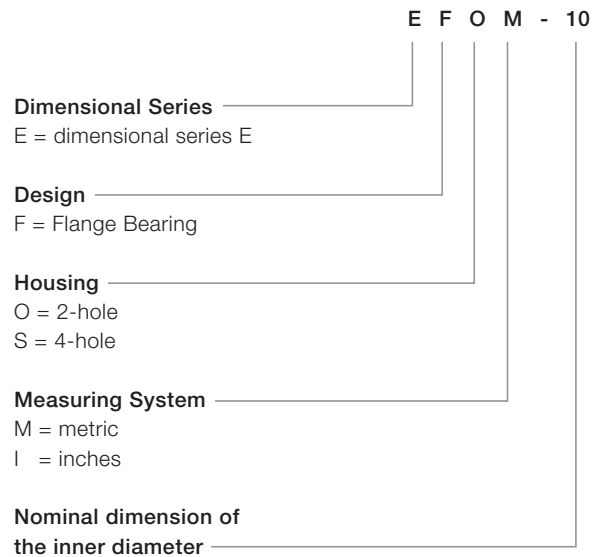

The example shows a metric 2-hole flange bearing of the dimensional series E with a spherical ball inner diameter of 10 mm.

Internet: <http://www.igus.com>
E-Mail: sales@igus.com
QuickSpec: www.igus.com/qs/igubal.asp



Reflector telescope in La Palma, Spain



igubal® flange bearing in the reflector adjustment of the telescope



Outdoor cleaning machine

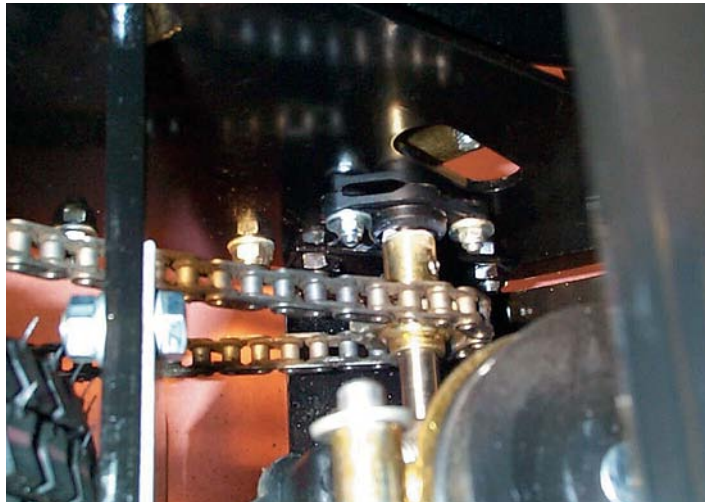

igubal® flange bearing in the drive shaft of the outdoor cleaning machine



Leaching system for bakery products

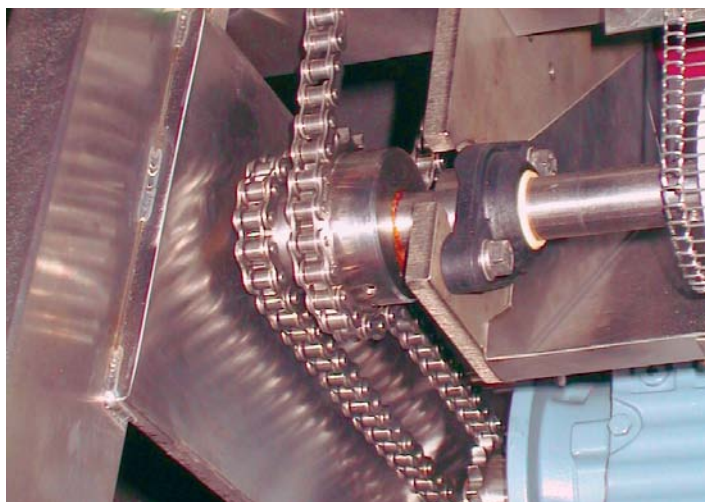

igubal® flange bearing in the drive of the conveyor belt

igubal®
Flange
Bearing

PDF: www.igus.com/pdf/igubal.asp
Specs/CAD/RFQ: www.igus.com/igubal.asp
RoHS info: www.igus.com/RoHS.asp



inch

mm



igubal® Flange Bearing, 4 Hole - Inch - EFSI

EFSI

igubal® Flange Bearing

Telephone 1-888-803-1895
Fax 1-401-438-7680

Internet: <http://www.igus.com>
E-Mail: sales@igus.com
QuickSpec: www.igus.com/qs/igubal.asp



Special Properties

- housing made of igumid® G
- spherical ball made of highly wear-resistant iglide® L280 and iglide® R
- easy to install
- compensation for alignment errors
- universal corrosion resistance
- lightweight
- maintenance-free, self-lubricating

with 4 mounting holes

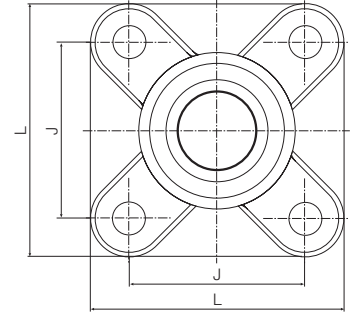
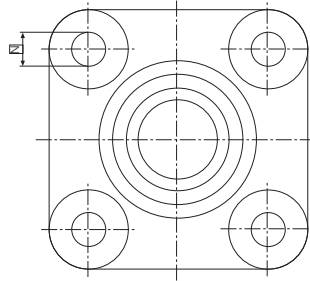
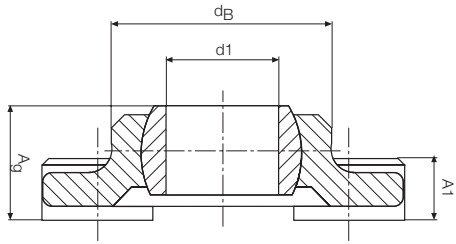

Dimensions (inch)

Part Number	d1 h10	dB	L Width	J	A1 Height of Plate	Ag Height Total	N Mounting Holes h13	Max. Permissible Load on the Spherical Ball (lbs)	Max. Permissible Tensile Strength Force (lbs)
EFSI-03	.190	.551	.984	.669	.177	.311	.126	45	225
EFSI-04	.250	.551	.984	.669	.177	.343	.126	45	225
EFSI-05	.313	.709	1.299	.866	.217	.413	.169	90	315
EFSI-06	.375	.866	1.496	1.024	.256	.484	.209	112	450
EFSI-07	.437	.984	1.575	1.102	.276	.520	.209	135	562
EFSI-08	.500	.984	1.575	1.102	.276	.520	.209	135	562
EFSI-10	.625	1.260	2.047	1.417	.354	.654	.252	281	719
EFSI-12	.750	1.575	2.559	1.772	.433	.787	.331	427	899
EFSI-16	1.000	1.909	2.913	2.047	.551	.965	.331	585	1259

Part Number	d1 h10	dB	L Width	J	A1 Height of Plate	Ag Height Total	N Mounting Holes h13	Max. Permissible Load on the Spherical Ball (lbs)	Max. Permissible Tensile Strength Force (lbs)
EFSI-03R	.190	.551	.984	.669	.177	.311	.126	45	225
EFSI-04R	.250	.551	.984	.669	.177	.343	.126	45	225
EFSI-05R	.313	.709	1.299	.866	.217	.413	.169	90	315
EFSI-06R	.375	.866	1.496	1.024	.256	.484	.209	112	450
EFSI-07R	.437	.984	1.575	1.102	.276	.520	.209	135	562
EFSI-08R	.500	.984	1.575	1.102	.276	.520	.209	135	562
EFSI-10R	.625	1.260	2.047	1.417	.354	.654	.252	281	719
EFSI-12R	.750	1.575	2.559	1.772	.433	.787	.331	427	899

Spherical ball material options ▶ Page 35.2

▶ Tolerance Table, Page 1.14



J4VEM:
Clearance-free



JEM: Low
Moisture absorption



REM:
Low Cost/Low Moisture
Available from stock



Special Properties

- housing made of igumid® G
- spherical ball made of highly wear-resistant iglide® L280 and iglide® R
- easy to install
- compensation for alignment errors
- universal corrosion resistance
- lightweight
- maintenance-free, self-lubricating

with 4 mounting holes

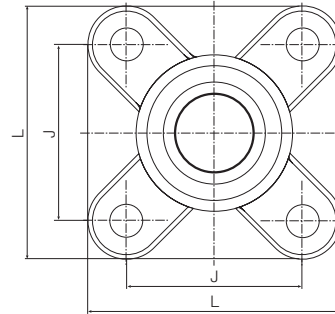
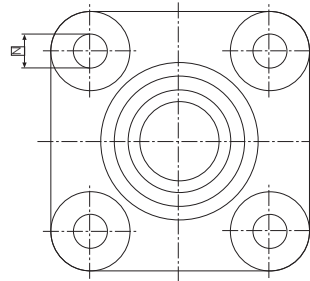
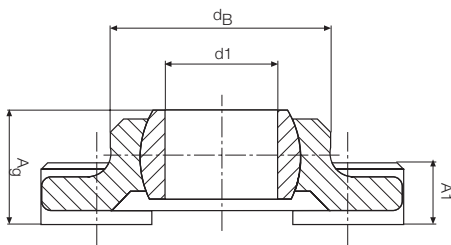

Dimensions (mm)

Part Number	d1 h10	dB	L Width	J	A1 Height of Plate	Ag Height Total	N Mounting Holes h13	Max. Permissible Load on the Spherical Ball (lbs)	Max. Permissible Tensile Strength Force (lbs)
EFSM-05	5	14.0	25.0	17.0	4.5	8.5	3.2	67	225
EFSM-06	6	14.0	25.0	17.0	4.5	8.5	3.2	67	225
EFSM-08	8	18.0	33.0	22.0	5.5	10.5	4.3	101	315
EFSM-10	10	22.0	38.0	26.0	6.5	12.0	5.3	157	450
EFSM-12	12	25.0	40.0	28.0	7.0	13.0	5.3	191	562
EFSM-15	15	30.0	49.0	34.0	8.5	15.5	6.4	247	674
EFSM-16	16	32.5	52.0	36.0	9.0	16.5	6.4	303	719
EFSM-17	17	35.0	54.0	38.0	10.0	18.0	6.4	360	764
EFSM-20	20	40.0	65.0	45.0	11.0	20.0	8.4	450	899
EFSM-25	25	48.5	74.0	52.0	14.0	25.0	8.4	540	1259
EFSM-30	30	55.0	85.0	60.0	15.0	26.0	10.5	629	1349

► Tolerance Table, Page 1.14

Spherical ball material options ► Page 35.2



J4VEM:
Clearance-free



JEM: Low
Moisture absorption



REM:
Low Cost/Low Moisture





igubal® Flange Bearing, 2 Hole - inch - EFOI

EFOI

igubal® Flange Bearing



with 2 mounting holes

Special Properties

- Housing made of igumid® G
- Spherical ball made of highly wear-resistant iglide® L280 and iglide® R
- Easy to install
- Compensation for alignment errors
- Universal corrosion resistance
- Lightweight
- Maintenance-free, self-lubricating

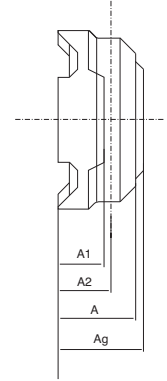
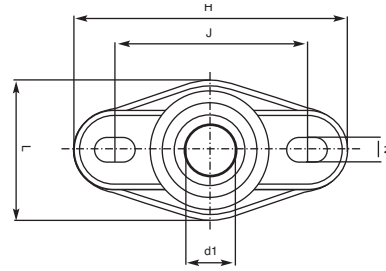
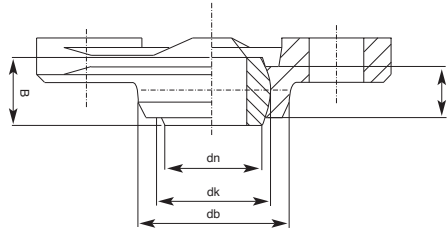

Load Data and Dimensions (mm)

Part Number	d1	dn	dk	dB	H	L	J	A1	Ag	A	A2
EFOI-03	.1875	.315	.394	.551	1.331	.630	.945	.177	.312	.303	.217
EFOI-04	.2500	.315	.394	.551	1.331	.630	.945	.177	.342	.303	.217
EFOI-05	.3125	.315	.394	.709	1.740	.866	1.220	.217	.412	.374	.256
EFOI-06	.3750	.315	.394	.866	2.047	1.024	1.417	.256	.483	.433	.295
EFOI-07	.4375	.512	.630	.984	2.232	1.220	1.614	.276	.518	.472	.315
EFOI-08	.5000	.394	.512	.984	2.232	1.220	1.614	.276	.518	.472	.315
EFOI-10	.6250	.512	.630	1.260	2.858	1.496	2.087	.394	.683	.622	.433
EFOI-12	.7500	.590	.710	1.575	3.504	1.850	2.559	.433	.785	.728	.472
EFOI-16	1.0000	.768	.945	1.909	3.976	2.303	2.953	.551	.966	.925	.581

Part Number	N d x l	B	C1	Max. Angle of Pivot	Max. Permissible Load on the Spherical Ball (lbs)	Max. Permissible Tensile Strength Force (lbs)
EFOI-03	0.126 x 0.197	.190	0.173	33°	90	169
EFOI-04	0.126 x 0.197	.250	0.173	27°	112	180
EFOI-05	0.169 x 0.256	.313	0.236	24°	157	247
EFOI-06	0.210 x 0.315	.375	0.276	24°	191	450
EFOI-07	0.210 x 0.315	.406	0.315	21°	247	495
EFOI-08	0.210 x 0.315	.406	0.315	21°	247	495
EFOI-10	0.212 x 0.315	.500	0.374	24°	315	629
EFOI-12	0.331 x 0.492	.625	0.512	17°	405	1236
EFOI-16	0.331 x 0.492	.750	0.669	14°	674	1349

Spherical ball material options ▶ Page 35.2



J4VEM:
Clearance-free



JEM: Low
Moisture absorption



REM:
Low Cost/Low Moisture
Available from stock

Telephone 1-888-803-1895
Fax 1-401-438-7680

Internet: <http://www.igus.com>
E-Mail: sales@igus.com
QuickSpec: www.igus.com/qs/igubal.asp

igubal® Flange Bearing, 2 Hole - mm - EFOM



Special Properties



- Housing made of igumid® G
- Spherical ball made of highly wear-resistant iglide® L280 and iglide® R
- Easy to install
- Compensation for alignment errors
- Universal corrosion resistance
- Lightweight
- Maintenance-free, self-lubricating

with 2 mounting holes

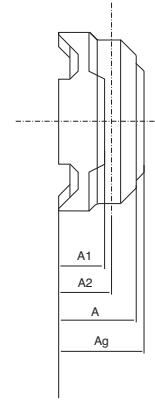
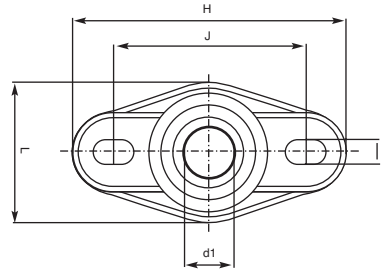
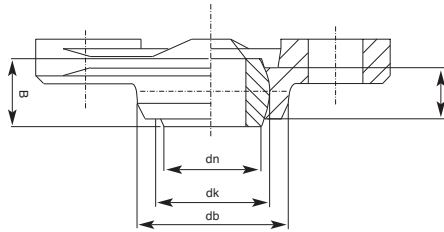

Load Data and Dimensions (mm)

Part Number	d1 E10	dn	dk	dB	H	L	J ±0,1	A1	Ag	A	A2
EFOM-05	5	8.00	10.00	14.0	33.8	16.0	24.0	4.5	8.5	7.70	5.50
EFOM-06	6	8.00	10.00	14.0	33.8	16.0	24.0	4.5	8.5	7.70	5.50
EFOM-08	8	10.00	13.00	18.0	44.2	22.0	31.0	5.5	10.5	9.50	6.50
EFOM-10	10	13.00	16.00	22.0	52.0	26.0	36.0	6.5	12.0	11.00	7.50
EFOM-12	12	15.00	18.00	25.0	56.7	31.0	41.0	7.0	13.0	12.00	8.00
EFOM-15	15	18.50	22.00	30.0	68.6	36.0	50.0	8.5	15.5	13.00	8.50
EFOM-16	16	19.50	24.00	32.0	72.6	38.0	53.0	10.0	17.5	15.80	11.00
EFOM-17	17	*	*	35.0	74.6	41.0	55.0	10.0	18.0	*	*
EFOM-20	20	24.00	29.00	40.0	89.0	47.0	65.0	11.0	20.0	18.50	12.00
EFOM-25	25	29.00	35.00	48.5	101.0	58.5	75.0	14.0	25.0	23.50	14.75
EFOM-30	30	34.00	40.00	55.0	118.0	65.0	87.5	15.0	26.0	24.50	15.00

Part Number	N d x l	B	C1	Shaft		Max. Angle of Pivot	Max. Permissible Load on the Spherical Ball (lbs)	Max. Permissible Tensile Strength Force (lbs)
				Min.	Max.			
EFOM-05	3.2 x 5.0	6.00	4.40	4.970	5.000	33°	56	169
EFOM-06	3.2 x 5.5	6.00	4.40	5.970	6.000	27°	56	180
EFOM-08	4.3 x 6.5	8.00	6.00	7.964	8.000	24°	156	247
EFOM-10	5.3 x 8.0	9.00	7.00	9.964	10.000	24°	191	450
EFOM-12	5.3 x 8.0	10.00	8.00	11.957	12.000	21°	247	495
EFOM-15	6.4 x 10.0	13.00	8.50	14.957	15.000	19°	292	540
EFOM-16	6.4 x 10.1	13.00	9.50	15.957	16.000	24°	314	629
EFOM-17	6.4 x 10.2	*	*	16.957	17.000	20°	359	719
EFOM-20	8.4 x 12.5	16.00	13.00	19.948	20.000	17°	404	1236
EFOM-25	8.4 x 12.6	20.00	17.00	24.948	25.000	14°	674	1349
EFOM-30	10.5 x 16.0	22.00	19.00	29.948	30.000	12°	787	1461

Spherical ball material options ▶ Page 35.2

▶ Tolerance Table, Page 1.14



J4VEM:
Clearance-free



JEM: Low
Moisture absorption



REM:
Low Cost/Low Moisture

igubal® Flange Bearing

EFOM

PDF: www.igus.com/pdf/igubal.asp
 Specs/CAD/RFQ: www.igus.com/igubal.asp
 RoHS info: www.igus.com/RoHS.asp

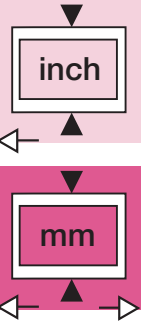
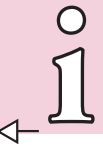



igubal® Flange Bearing - KFSM-GT

KFSM

igubal® Flange
Bearing

Telephone 1-888-803-1895
Fax 1-401-438-7680

Internet: <http://www.igus.com>
E-Mail: sales@igus.com
QuickSpec: www.igus.com/qs/igubal.asp



Special Properties

- Preassembled delivery
- Resistant to dirt
- Light weight
- For high static loads
- High stiffness
- Predictable lifetime
- Maintenance-free dry running

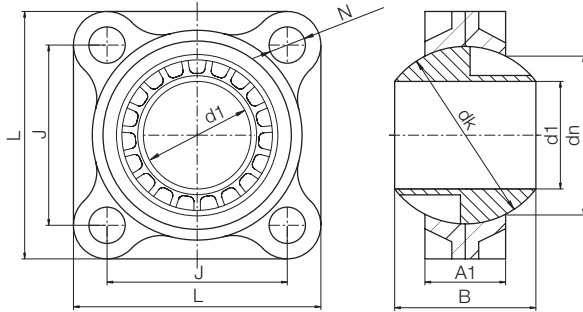

Dimensions (mm)

Part No.	d1 (E10)	dn	dk	A1	B	J	L	N	Max. pivot angle
KFSM-GT35	35.0	59.0	66.0	30.0	48.5	66.0	92.0	13.5	24°
KFSM-GT40	40.0	59.0	66.0	30.0	48.5	66.0	92.0	13.5	24°
KFSM-GT45	45.0	72.0	82.0	40.0	60.0	78.0	104.0	13.5	24°
KFSM-GT50	50.0	72.0	82.0	40.0	60.0	78.0	104.0	13.5	24°

Load data

Part No.	Maximum static tensile strength		Maximum static axial compressive strength	
	short term (lbs)	long term (lbs)	short term (lbs)	long term (lbs)
KFSM-GT35	1124.0	562.0	1011.6	505.8
KFSM-GT40	1124.0	562.0	1011.6	505.8
KFSM-GT45	1348.8	674.4	1213.9	607.0
KFSM-GT50	1348.8	674.4	1213.9	607.0

Spherical ball material options ▶ Page 35.2



J4VEM:
Clearance-free



JEM: Low
Moisture absorption



REM:
Low Cost/Low Moisture



With 2 mounting holes

Special Properties

- Temperatures to 392°F
- iglide® T500 highly wear resistant spherical ball
- Easy to install
- Compensation for alignment errors
- Corrosion resistance
- Light weight
- Maintenance-free, self-lubricating
- Chemical resistant
- Can be used under water

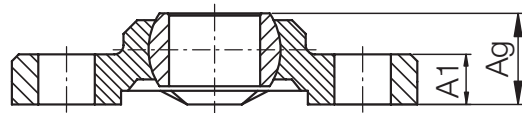
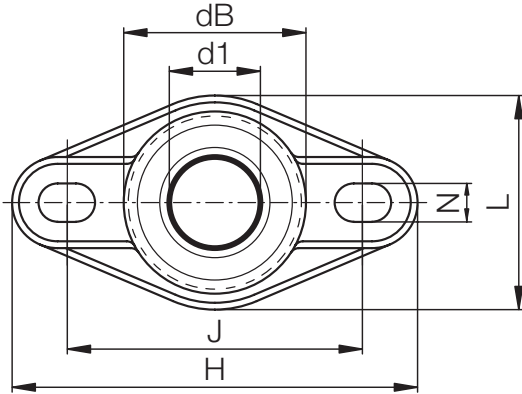

Dimensions (mm)

Part No	d1 E10	dB	H Size	L Width	J Hole Pitch	A ₁ Height of Plate	A ₉ Height Total	N Bore Diameter d x L	Max. Pivot Angle
	±0.1								
EFOM-06 HT	6	14,0	33,8	16,0	24,0	4,5	8,5	3,2 x 5,5	27°
EFOM-08 HT	8	18,0	44,2	22,0	31,0	5,5	10,5	4,3 x 6,5	24°
EFOM-10 HT	10	22,0	52,0	26,0	36,0	6,5	12,0	5,3 x 8,0	24°
EFOM-12 HT	12	25,0	56,7	31,0	41,0	7,0	13,0	5,3 x 8,0	21°

Available from stock

igubal® Flange
Bearing

KFSM

PDF: www.igus.com/pdf/igubal.asp
 Specs/CAD/RFQ: www.igus.com/igubal.asp
 RoHS info: www.igus.com/RoHS.asp

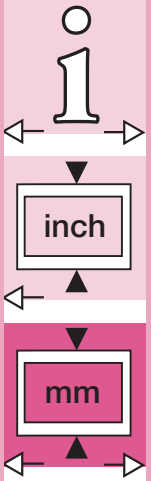

inch

mm



igubal® Flange Bearing - EFSM HT

igubal® Flange
Bearing

Telephone 1-888-803-1895
Fax 1-401-438-7680

Special Properties



- Temperatures to 392°F
- iglide® T500 highly wear resistant spherical ball
- Easy to install
- Compensation for alignment errors
- Corrosion resistance
- Light weight
- Maintenance-free, self-lubricating
- Chemical resistant
- Can be used under water

With 4 mounting holes

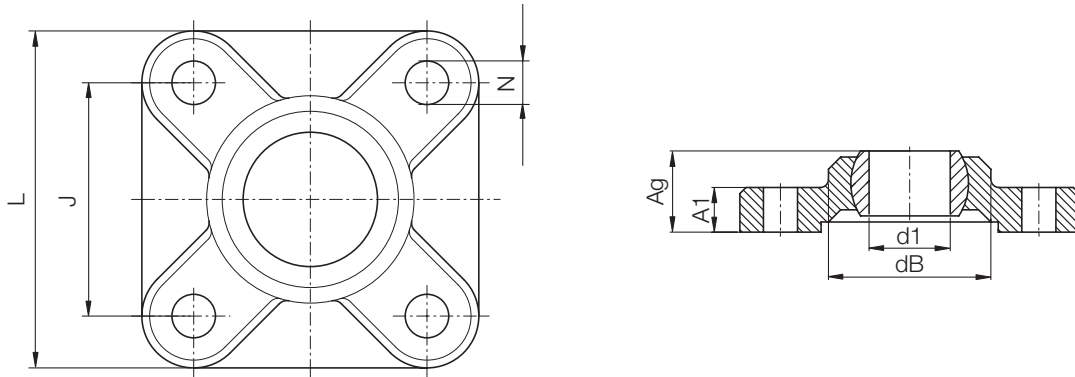

Dimensions (mm)

igubal® – Flange Bearing EFSM HT with 4 Mounting Holes

Part Number	d1 E10	dB	L Width	J Hole Pitch ±0.1	A ₁ Height of Plate	A ₉ Height Total	N Bore Diameter
EFSM-06 HT	6	14.0	25.0	17.0	4.5	8.5	3.2
EFSM-08 HT	8	18.0	33.0	22.0	5.5	10.5	4.3
EFSM-10 HT	10	22.0	38.0	26.0	6.5	12.0	5.3
EFSM-12 HT	12	25.0	40.0	28.0	7.0	13.0	5.3

Available from stock

Clearance-free spherical ball option



J4VEM: Clearance-free spherical ball

► Page 34.6

Internet: <http://www.igus.com>
E-Mail: sales@igus.com
QuickSpec: www.igus.com/qs/igubal.asp

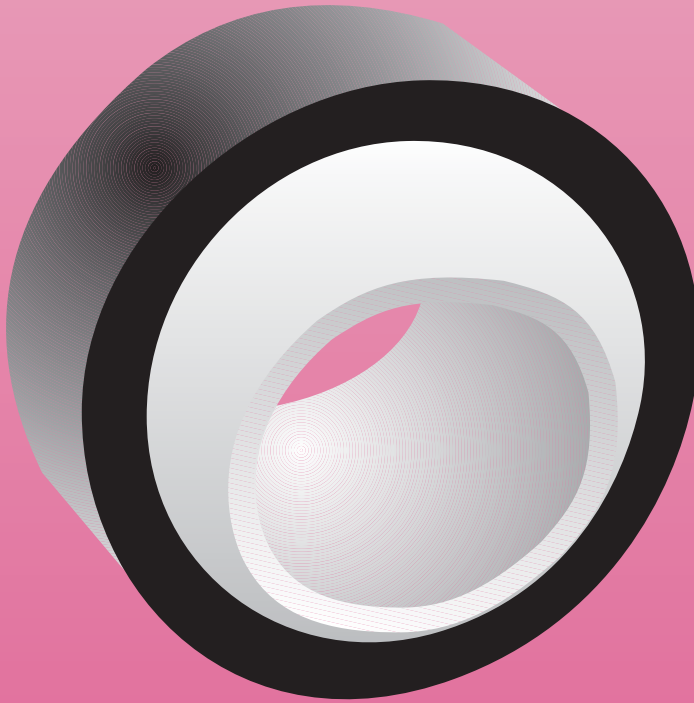

igubal[®] Pivoting Bearing

- Easy to install
- Extremely cost-effective
- Resistant to chemicals
- Lightweight
- High strength





igubal® Pivoting Bearing

igubal® Pivoting
Bearing

Telephone 1-888-803-1895
Fax 1-401-438-7680

Internet: <http://www.igus.com>
E-Mail: sales@igus.com
QuickSpec: www.igus.com/qs/igubal.asp



igubal® Pivoting Bearings

The use of pivoting bearings is usually associated with high weight materials, difficult installation, and high costs. Most of the time, maintenance is still necessary over the long term, and the bearings are only corrosion-resistant in special designs. Often roller bearings or plain bearings malfunction prematurely due to high edge loads, or bearings must be readjusted, reamed, or retrofit in order to compensate for alignment errors.

igubal® pivoting bearings put an end to all of these disadvantages and open up many new possibilities for your engineering design.

igubal® Pivoting Bearings are:

- easy to install
- exceptionally cost-effective
- lightweight
- high strength

Area of Application

Ease of installation makes diverse applications possible for igubal® pivoting bearings. They can be used anywhere the self-adjusting feature offers design advantages or helps to simplify assembly.

Tolerances

Maintenance-free igubal® pivoting bearings are meant to be oversized before being pressfit. After proper installation into a recommended housing bore, the inner diameter adjusts to meet our specified tolerances. Please adhere to the catalog specifications for housing bore and recommended shaft sizes. This will help to ensure optimal performance of iglide plain bearings. Please contact an iglide® technical expert for support.

► Tolerance Table, Page 1.14

Installation

igubal® pivoting bearings are pressfit into a recommended housing bore and axially secured. An exact orientation of the bearing housing is not necessary, since the pivoting bearing compensates for alignment errors.

Dimensions

igubal® pivoting bearings are manufactured according to DIN ISO 12240 in the dimensional series K and E.

The product range provides dimensions from .19 to 1.0" and 3 to 30 mm. Please contact us if you need other dimensions.

Structure for the part numbers for igubal® pivoting bearings

The part numbers of igubal® pivoting bearings are designed according to the following system:

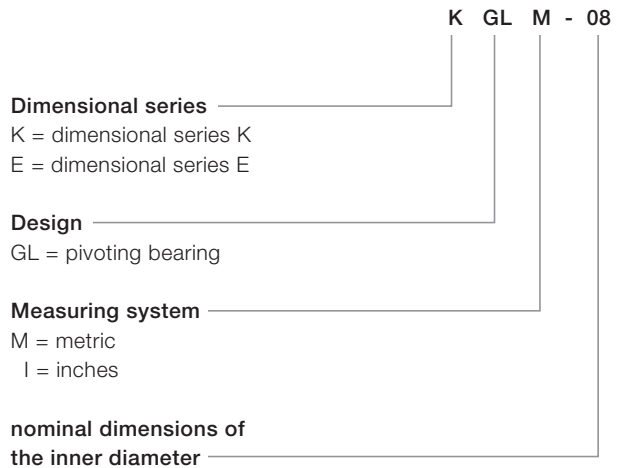

The example shows a metric pivoting bearing of the dimensional series K with a pivoting ball inner diameter of 8 mm.

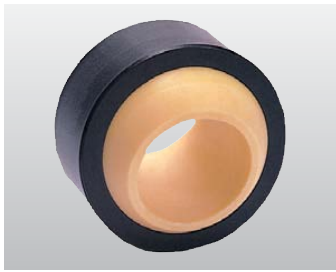

Special Properties

- housing made of igumid G
- spherical ball made of highly wear-resistant iglide® L280
- easy to install
- compensation for alignment errors
- universal corrosion resistance
- lightweight
- maintenance-free, self-lubricating

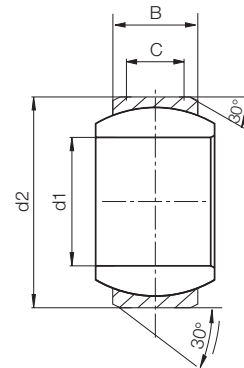

Load Data and Dimensions (inch)

Part No.	d1 E10	d2 Inch	B Inch	C Inch	Maximum Angle of Pivot
KGLI-03	.1900	.5625	.312	.218	34°
KGLI-04	.2500	.6562	.375	.250	30°
KGLI-05	.3125	.7500	.437	.281	29°
KGLI-06	.3750	.8125	.500	.312	25°
KGLI-07	.4375	.9375	.562	.343	25°
KGLI-08	.5000	1.0625	.625	.390	25°
KGLI-10	.6250	1.1875	.750	.500	23°
KGLI-12	.7500	1.4375	.875	.593	23°
KGLI-16	1.0000	2.1250	1.375	1.005	23°

Part No.	Maximum Static Compressive Strength		Maximum Torque for the assembly ft lbs	Housing Bore		Shaft Size	
	radial lbs	axial lbs		Min	Max.	Min.	Max.
KGLI-03	225	34	3.69	.5625	.5630	.1888	.1900
KGLI-04	337	56	7.37	.6562	.6568	.2485	.2500
KGLI-05	450	79	8.85	.7500	.7509	.3110	.3125
KGLI-06	629	90	14.75	.8125	.8134	.3735	.3750
KGLI-07	843	101	22.13	.9375	.9382	.4358	.4375
KGLI-08	955	112	25.82	1.0625	1.0632	.4983	.5000
KGLI-10	1191	169	29.50	1.1875	1.1882	.6233	.6250
KGLI-12	1911	191	40.57	1.4375	1.4383	.7479	.7500
KGLI-16	3057	562	47.94	2.1250	2.1258	.9988	1.0000

► Tolerance Table, Page 1.14
 For housing bores (H7)
 For shaft sizes (h7)

igubal® Pivoting
Bearing

KGLI

PDF: www.igus.com/pdf/igubal.asp
 Specs/CAD/RFQ: www.igus.com/igubal.asp
 RoHS info: www.igus.com/RoHS.asp

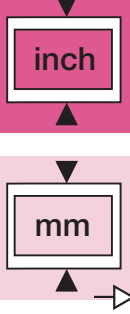



igubal® Pivoting Bearing - mm - KGLM

KGLM

igubal® Pivoting
Bearing

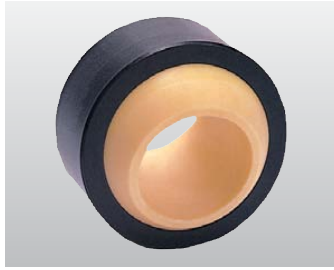

Special Properties

- housing made of igumid® G
- standard ball made from iglide® L280, other options are available
- easy to install
- compensation for alignment errors
- universal corrosion resistance
- lightweight
- maintenance-free, self-lubricating

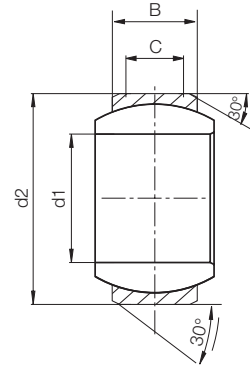

Load Data and Dimensions (mm)

Part No.	Maximum Static Compressive Strength		Maximum Torque for the Assembly (ft lbs)	d1 mm E10	d2 mm	B mm	C mm	Maximum Angle of Pivot
	Radial (lbs)	Axial (lbs)						
KGLM-03	119	34	2.2	3	10	6	4.5	32°
KGLM-05	281	56	3.7	5	13	8	6.0	30°
KGLM-06	393	90	7.4	6	16	9	6.5	29°
KGLM-08	528	180	8.9	8	19	12	9.0	25°
KGLM-10	798	202	14.8	10	22	14	10.5	25°
KGLM-12	944	214	22.1	12	26	16	12.0	25°
KGLM-14	1281	270	25.8	14	28	19	13.5	23°
KGLM-16	1686	292	29.5	16	32	21	15.0	23°
KGLM-18	1910	315	33.2	18	35	23	16.5	23°
KGLM-20	2203	427	40.6	20	40	25	18.0	23°
KGLM-22	2630	584	44.3	22	42	28	20.0	22°
KGLM-25	3057	674	47.9	25	47	31	22.0	22°
KGLM-30	4496	731	51.6	30	55	37	25.0	22°

► Tolerance Table, Page 1.14
For housing bores (H7)
For shaft sizes (h7)

Internet: <http://www.igus.com>
E-Mail: sales@igus.com
QuickSpec: www.igus.com/qs/igubal.asp

igubal® Pivoting Bearing - mm - EGLM

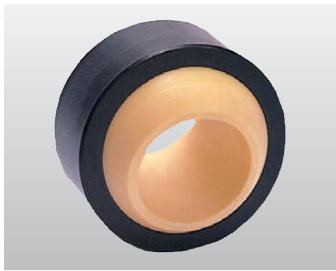

Special Properties

- housing made of igumid G
- standard ball made from iglide® L280, other options are available
- easy to install
- compensation for alignment errors
- universal corrosion resistance
- lightweight
- maintenance-free, self-lubricating

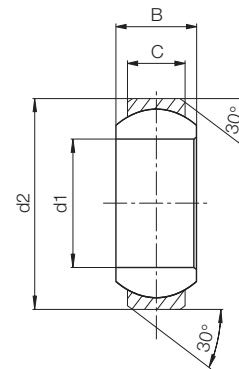

Load Data and Dimensions (mm)

Part No.	Maximum Static Compression		Maximum Torque the Assembly (ft lbs)	d1 mm E10	d2 mm	B mm	C mm	Maximum Angle of Pivot
	Radial (lbs)	Axial (lbs)						
EGLM-04	135	11	1.5	4	12	5	3.0	37°
EGLM-05	213	22	1.5	5	14	6	4.0	33°
EGLM-06	236	28	1.8	6	14	6	4.0	27°
EGLM-08	303	39	5.2	8	16	8	5.0	24°
EGLM-10	449	67	10.3	10	19	9	6.0	24°
EGLM-12	505	101	18.4	12	22	10	7.0	21°
EGLM-15	775	112	22.1	15	26	12	9.0	21°
EGLM-16	876	135	23.6	16	28	13	9.5	21°
EGLM-17	921	157	25.8	17	30	14	10.0	21°
EGLM-20	1202	269	29.5	20	35	16	12.0	18°
EGLM-25	1843	393	40.6	25	42	20	16.0	16°
EGLM-30	2472	562	51.6	30	47	22	18.0	13°

► Tolerance Table, Page 1.14
 For housing bores (H7)
 For shaft sizes (h7)

igubal® Pivoting Bearing

EGLM

PDF: www.igus.com/pdf/igubal.asp
 Specs/CAD/RFQ: www.igus.com/igubal.asp
 RoHS info: www.igus.com/RoHS.asp

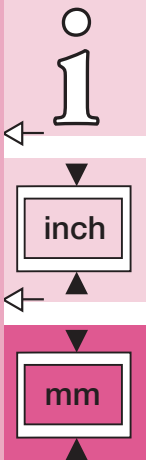

Spherical ball material options ► Page 35.2



RKM:
Low Cost/Low Moisture



XKM: High temperatures



JKM: Low moisture absorption



standard spherical ball with metal sleeve



igubal® Pivoting Bearing - KGLM SL - Slimline

KGLM SL

igubal® Spherical
Bearing

Telephone 1-888-803-1895
Fax 1-401-438-7680

Telephone 1-888-803-1895
Fax 1-401-438-7680

Internet: <http://www.igus.com>
E-Mail: sales@igus.com
QuickSpec: www.igus.com/qs/igubal.asp



Special Properties

- extremely narrow installation space
- load data compares with KGLM
- angle compensation to 5°
- maintenance-free
- corrosion-free
- low weight

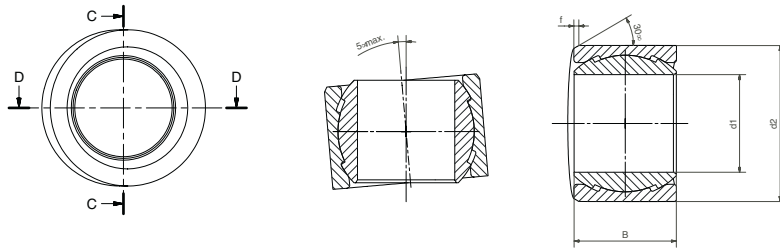

Load Data

Part Number	Max. static compressive strength (short term)		Max. static compressive strength (long term)	
	radial (lbs)	axial (lbs)	radial (lbs)	axial (lbs)
KGLM-08 SL	607	101	304	51
KGLM-10 SL	899	169	450	84
KGLM-12 SL	1012	169	506	84
KGLM-16 SL	1461	112	731	56

Dimensions (mm)

Part Number	d1 E10 (mm)	d2 (mm)	B (mm)	f (mm)	Max. Pivot Angle
KGLM-08 SL	8	14	9.0	0.5	5°
KGLM-10 SL	10	16	10.5	0.5	5°
KGLM-12 SL	12	18	12.0	0.5	5°
KGLM-16 SL	16	22	15.0	0.5	5°

Available from stock



Special Properties

- standard ball made from iglide® L280, other options are available
- easy to fit
- low Cost

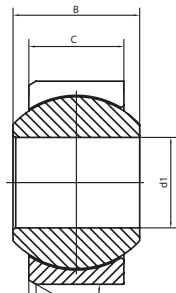
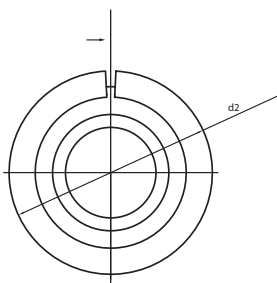

Load Data

Part Number	Max. static compressive strength (short term)		Max. static compressive strength (long term)	
	radial (lbs)	axial (lbs)	radial (lbs)	axial (lbs)
KGLM-10 LC	899	315	450	157
KGLM-12 LC	1214	337	607	169
KGLM-16 LC	1798	674	899	337
KGLM-20 LC	2248	1124	1124	562
KGLM-25 LC	3057	1686	1529	843
KGLM-30 LC	4496	2023	2248	1012

Dimensions (mm)

Part Number	d1 E10 (mm)	d2 (mm)	B (mm)	C (mm)	f (mm)	Max. Pivot Angle
KGLM-10 LC	10	22.0	14	10.5	0.8	25°
KGLM-12 LC	12	26.0	16	12	0.8	30°
KGLM-16 LC	16	32.0	21	15	0.8	30°
KGLM-20 LC	20	40.0	25	18	0.8	30°
KGLM-25 LC	25	47.0	31	22	0.8	30°
KGLM-30 LC	30	55.0	37	25	1.0	22°

Spherical ball material options ▶ Page 35.2



RKM:
Low Cost/Low Moisture



XKM: High
temperatures



JKM: Low
moisture absorption



standard spherical ball
with metal sleeve

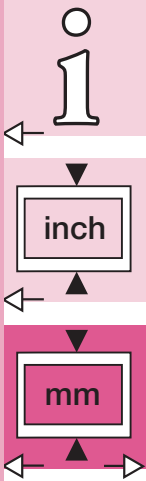



igubal® Pivoting Bearing - ECLM - Clip

ECLM

igubal® Spherical
Bearing

Special Properties



- standard ball made from iglide® J, other options are available
- Extremely easy installation - just clip into sheet metal
- No additional axial retainer required
- Extremely low installation space; space-saving thin wall design
- Maintenance-free iglide® spherical balls
- Diameters 6 to 16 mm

Interesting for many types of sheet metal applications

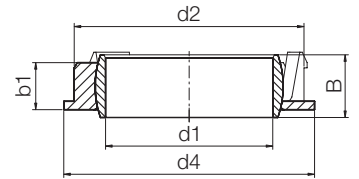
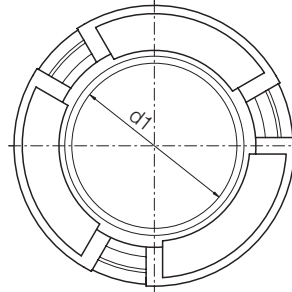

Dimensions (mm)

Part No.	Ø Ball Inside mm d1	Ball Width mm B	Ø Ball Outside mm dk	Ø Outside mm d2	Ø Flange mm d4	Thickness Housing mm b1	Pivoting Angle	Snap Groove Inner S1	Snap Groove Outer S2
ECLM-05-02	5	6	12.40	12	13	4.3	25°		
ECLM-06-02	6	6	12.40	16	17	4.3	18°		
ECLM-08-02	8	6	12.40	16	17	4.3	16°		
ECLM-10-03	10	6	12.40	16	17	4.5	12°	3.2	5.5
ECLM-12-03	12	6	14.20	18	19	4.5	12°	3.2	5.5
ECLM-16-03	16	6	18.00	22	24	4.5	12°	3.2	5.5

Part No.	Max. Static Short Term Force		Max. Static Long Term Force		Max. Cyclic Force	
	Maximum Radial Pressure lbs	Maximum Axial Pressure lbs	Maximum Radial Pressure lbs	Maximum Axial Pressure lbs	Maximum Radial Pressure lbs	Maximum Axial Pressure lbs
ECLM-05-02	157	5.62	79	2.70	47	1.69
ECLM-06-02	157	5.62	79	2.70	47	1.69
ECLM-08-02	225	5.62	112	2.70	67	1.69
ECLM-10-03	315	6.74	157	1.57	94	2.02
ECLM-12-03	405	7.87	202	2.25	121	2.25
ECLM-16-03	629	10.11	315	4.50	189	3.03

Spherical ball material options ▶ Page 35.2



RKM:
Low Cost/Low Moisture
Available from stock



XKM: High
temperatures



JKM: Low
moisture absorption



standard spherical ball
with metal sleeve

Telephone 1-888-803-1895
Fax 1-401-438-7680

Internet: <http://www.igus.com>
E-Mail: sales@igus.com
QuickSpec: www.igus.com/qs/igubal.asp



igubal® Spherical Bearing ECLM HD



Special Properties

- standard ball made from iglide® L280, other options are available
- High axial and radial loads
- Easily clips into sheet metal
- No additional axial fastening necessary
- Extremely compact design and installation
- Adjustment of axial and radial clearance by pre-loading
- Maintenance-free iglide® spherical balls
- For sheet thickness 5 mm

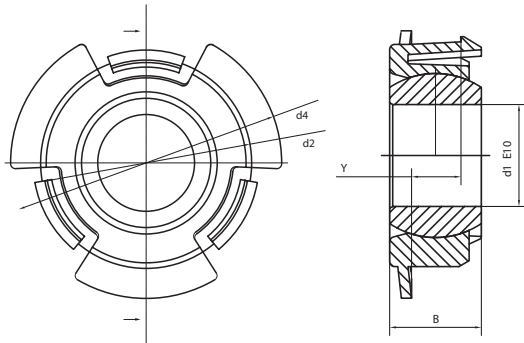

Load Data

Part Number	Maximum static Compression Force (Short term)		Maximum static long term Compression (Long term)	
	radial (N)	axial (N)	radial (N)	axial (N)
ECLM-10-05 HD	2500	150	1250	75

Dimensions [mm]

Part Number	Ø Spherical Ball d1 E10	Spherical Ball Width B	Ø outside d2 ±0.15	Ø Collar d4	Sheet-thickness Y ±0.1	Pivot Angle α
ECLM-10-05 HD	10,0	9,0	22,0	28	5,0	24°

Spherical ball material options ▶ Page 35.2



RKM:
Low Cost/Low Moisture



XKM: High temperatures



JKM: Low moisture absorption



standard spherical ball with metal sleeve

PDF: www.igus.com/pdf/igubal.asp
 Specs/CAD/RFQ: www.igus.com/igubal.asp
 RoHS info: www.igus.com/RoHS.asp

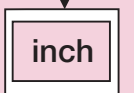



igubal® Pivoting Bearing - EGFM - Clip

EGFM

igubal® Pivoting Bearing

Telephone 1-888-803-1895
Fax 1-401-438-7680

Internet: <http://www.igus.com>
E-Mail: sales@igus.com
QuickSpec: www.igus.com/qs/igubal.asp



Special Properties

- standard ball made from iglide® L280, other options are available
- maintenance-free, dry-running
- easy to fit
- can compensate for a housing tolerance of ± 0.2 mm

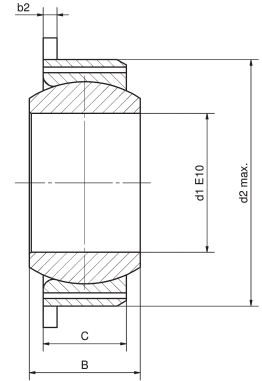
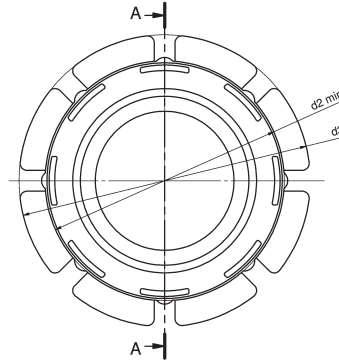

Dimensions (mm)

Part No.	d1 (mm)	d2 min. (mm)	d2 max. (mm)	d3 (mm)	C (mm)	B (mm)	b2 (mm)	Housing min.	Housing max.	Max. pivoting angle
EGFM-08 T SL	8 (H10)	15.8	16.5	18	5.0	6	1.1	15.8	16.2	11°
EGFM-16 T	16 (E10)	29.8	30.6	35	9.5	13	1.5	29.8	30.2	21°
EGFM-20 T	20 (E10)	34.8	35.6	42	12.0	16	2.0	34.8	35.2	18°
EGFM-25 T	25 (E10)	41.8	42.6	50	16.0	20	2.0	41.8	42.2	16°
EGFM-30 T	30 (E10)	46.8	47.6	55	18.0	22	2.0	46.8	47.2	13°

Load data

Part Number	Maximum static Compression Force (Short term)		Maximum static Compression Force (Long term)	
	radial (lbs)	axial (lbs)	radial (lbs)	axial (lbs)
EGFM-08 T SL	247.3	33.7	123.6	16.8
EGFM-10 T	427.1	49.5	213.6	24.7
EGFM-12 T	562.0	60.7	281.0	30.4
EGFM-16 T	1348.9	134.9	674.4	67.4
EGFM-20 T	2023.3	179.8	1011.6	89.9
EGFM-25 T	3147.3	629.5	1573.7	314.7
EGFM-30 T	3821.8	674.4	1910.9	337.2

Spherical ball material options ▶ Page 35.2



RKM:
Low Cost/Low Moisture



XKM: High
temperatures



JKM: Low
moisture absorption



standard spherical ball
with metal sleeve

igubal® Pivoting Bearing - Double Joint



Special Properties

- standard ball made from iglide® L280, other options are available
- maintenance-free, self-lubricating
- mechanical joining link between 2 components
- self-aligning to compensate for angular errors
- corrosion-resistant
- constant movements
- special lengths often possible, please contact igubal®

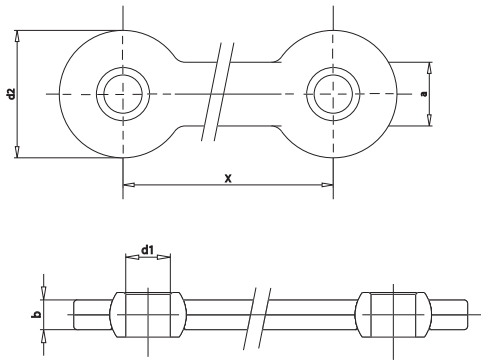

Structure for the part numbers for igubal® Double Joint bearings

The part numbers of igubal® double joint bearings are designed according to the following system:

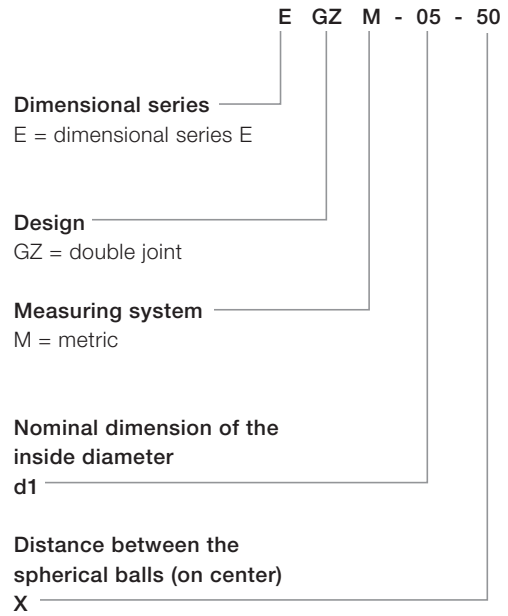

Part No.	Maximum Static Tensile Strength		Maximum Static Axial Compressive Strength		d1 mm	d2 mm	X mm	b mm	a mm
	Short Term	Long Term	Short Term	Long Term					
	lbs	lbs	lbs	lbs	E10				
EGZM-04-25	247	124	292	146	04	20	25	4	10
EGZM-04-50	247	124	169	84	04	20	50	4	10
EGZM-04-75	247	124	112	56	04	20	75	4	10
EGZM-05-25	247	124	292	146	05	20	25	4	10
EGZM-05-50	247	124	169	84	05	20	50	4	10
EGZM-05-75	247	124	112	56	05	20	75	4	10
EGZM-06-25	247	124	292	146	06	20	25	4	10
EGZM-06-50	247	124	169	84	06	20	50	4	10
EGZM-06-75	247	124	112	56	06	20	75	4	10
EGZM-08-60	674	337	787	393	08	30	60	7	15
EGZM-08-100	674	337	427	214	08	30	100	7	15
EGZM-10-60	562	281	787	393	10	30	60	7	15
EGZM-10-100	562	281	427	214	10	30	100	7	15
EGZM-12-60	450	225	787	393	12	30	60	7	15
EGZM-12-100	450	225	427	214	12	30	100	7	15

► Tolerance Table, Page 1.14

Spherical ball material options ► Page 35.2



RKM:
Low Cost/Low Moisture



XKM: High
temperatures



JKM: Low
moisture absorption



standard spherical ball
with metal sleeve

igubal® Spherical
Bearing
EGZM

PDF: www.igus.com/pdf/igubal.asp
Specs/CAD/RFQ: www.igus.com/igubal.asp
RoHS info: www.igus.com/RoHS.asp

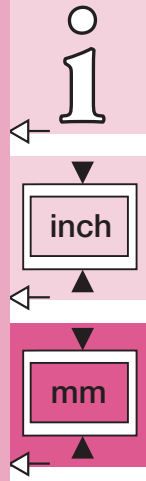



igubal® Pivoting Bearing - Custom

igubal® Spherical
Bearing

Telephone 1-888-803-1895
Fax 1-401-438-7680

Internet: <http://www.igus.com>
E-Mail: sales@igus.com
QuickSpec: www.igus.com/qs/igubal.asp

Custom Solutions

- Custom-made igubal® spherical bearings starting from medium batch sizes
- Short delivery times
- Low-cost production
- We can manufacture spherical balls in different iglide® materials
- Maintenance-free





igubal[®] Spherical Thrust

- Easy to install
- Compensation for misalignment
- Compensation for edge loads
- Very good friction and wear properties





igubal® Spherical Thrust Bearing

igubal® Spherical Thrust Bearing

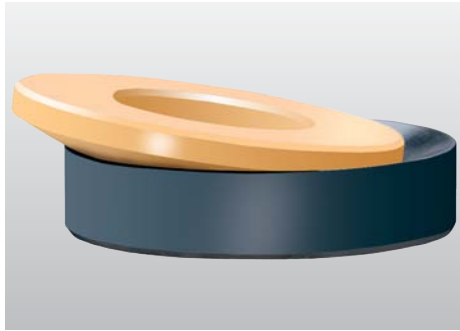

The self-adjusting igubal® spherical thrust bearings are very easy to install and help to compensate for alignment errors and prevent edge loads.

The housing pad is made of the impact-resistant, thermoplastic composite material igumid G. The spherical disk is made to the same standard as iglide® L280 plain bearings. This combination produces especially good friction and wear properties.

Loads

The loading capacity of igubal® spherical thrust bearings is very high for standard ambient temperatures. For high continuous loads and high temperatures, the loading capacity of the thrust bearings should be tested to your application requirements in an experiment that duplicates the application.

Coefficients of Friction and Speeds

Taking into account the radial load, maximum surface speeds up to 98 fpm rotating are possible.

Installation

The housing pad is installed so that it is countersunk and secured. The spherical washer is loosely fitted in the socket and is held in place by the shaft that is placed into the bearing.

Product Range

igubal® spherical thrust bearings are provided as standards in dimensions from 5 to 20 mm. Please contact us if you need other dimensions

Structure for part numbers for igubal® spherical thrust bearings

The part numbers of igubal® spherical thrust bearings are designed according to the following system:

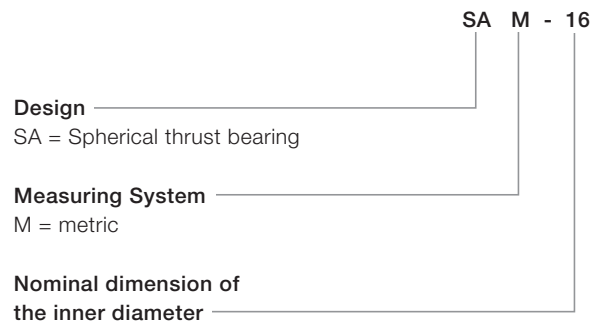

The example shows a spherical thrust bearing with metric dimensions and an inner diameter of 16mm.

Telephone 1-888-803-1895
Fax 1-401-438-7680

Telephone 1-888-803-1895
Fax 1-401-438-7680

Internet: <http://www.igus.com>
E-Mail: sales@igus.com
QuickSpec: www.igus.com/qs/igubal.asp

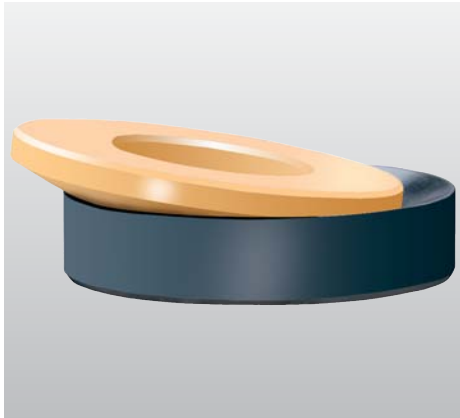

Spherical Disk

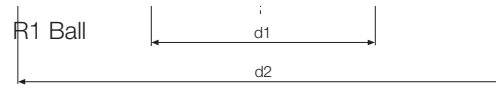

Ball Socket

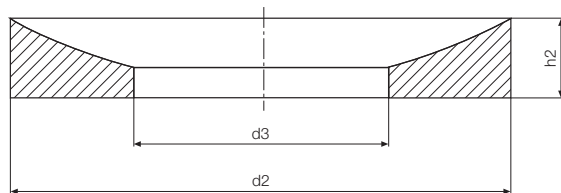

Load Data

Part No.	Maximum Static Axial Tensile Strength Short-term	Maximum Static Axial Tensile Strength Long-term
	(N)	(N)
SAM-05	899	449
SAM-06	1124	562
SAM-08	1798	899
SAM-10	2248	1124
SAM-12	2697	1348
SAM-16	3821	1910
SAM-20	4945	2492

Dimensions (mm)

Part No.	d1 Ball Socket DIN 7168	d3 Spherical Disk DIN 7168	d2	h1 Ball Socket	h2 Spherical Disk	H Total Height	R1 Radius	Compensation Angle	Total- Weight (g)
SAM-05	7.0	5.2	15.0	3.0	3.5	4.7	15.0	3°	0.9
SAM-06	7.5	6.2	16.0	3.0	4.0	5.7	16.0	3°	1.1
SAM-08	10.0	8.2	20.0	4.0	5.0	6.4	20.0	2°	2.2
SAM-10	12.0	10.2	24.0	4.5	5.5	7.3	24.0	2°	3.4
SAM-12	14.5	12.2	30.0	5.0	6.0	7.9	32.0	2°	5.9
SAM-16	19.0	16.5	36.0	5.5	6.5	8.5	40.0	2°	8.5
SAM-20	23.0	20.2	44.0	6.0	7.0	8.4	45.0	2°	13.1

Available from stock





igubal® Spherical Thrust Bearing

igubal® Spherical
Thrust Bearing

Telephone 1-888-803-1895
Fax 1-401-438-7680

Internet: <http://www.igus.com>
E-Mail: sales@igus.com
QuickSpec: www.igus.com/qs/igubal.asp

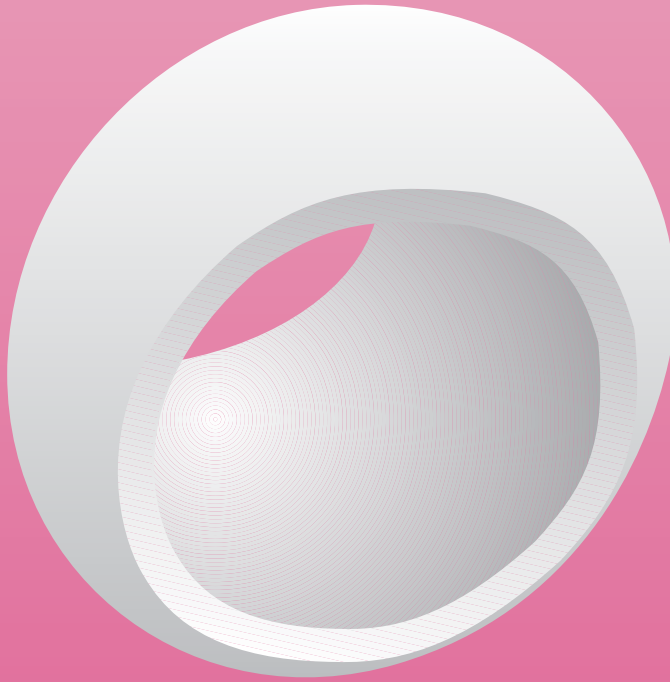

igubal® Spherical Balls

- Maintenance-free, self-lubricating
- Corrosion-resistant
- High compressive strength
- High elasticity
- Lightweight





igus® igubal® Spherical Balls



Every single iglide® material has its own special properties, which determines the suitability for your special applications and requirements. Today, we offer you spherical bearings from iglide® materials L280 (standard), J, J4, R, UW and T500. You can find detailed information about every material in the catalog chapters, starting at page 2.1.

Special Properties:

- Maintenance-free, self-lubricating
- Suitable for rotating, oscillating and linear movements
- Light weight

Tolerances

The maintenance-free igubal® spherical bearings have an inside diameter tolerance of E10. The shaft should be tolerated h6 to h9.

Structure for Part Numbers of igubal® Spherical Bearings

The part numbers of igubal® Spherical bearings are designed according to the following system:

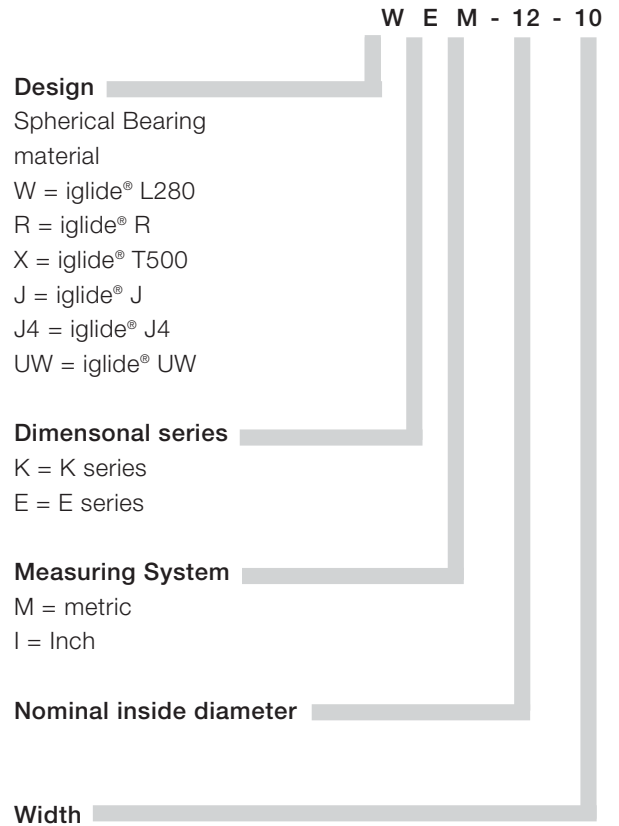

Spherical bearings – Material data

iglide® L280 (standard) – extreme wear resistance
 ► Chapter 7

iglide® R
 low cost
 low friction values
 ► Chapter 3

iglide® T500
 for high temperatures
 resistant to chemicals
 ► Chapter 12

iglide® J
 low friction values
 moisture absorption
 ► Chapter 4

iglide® J4
 ► xx.x

iglide® UW
 for under water applications
 ► xx.x

Housing Bore Recommendations

Nominal Size	METRIC	
	Min.	Max.
8	16.000	16.018
10	19.000	19.021
12	22.000	22.021
16	26.000	26.021
20	32.000	32.025
25	40.000	40.025
30	47.000	47.025
40	62.000	62.030
50	75.000	75.030

Housing Bore Recommendations

Nominal Size	INCH	
	Min.	Max.
1/4	.5000	.5007
3/8	.6250	.6257
1/2	.8750	.8758
5/8	1.1250	1.1258
3/4	1.250	1.251
1	1.5625	1.563
1-1/4	2.000	2.001
1-1/2	2.3750	2.376
2	3.000	3.001



igubal® Spherical Balls - WKI, WEI

Standard – iglide® L280; extreme wear resistance

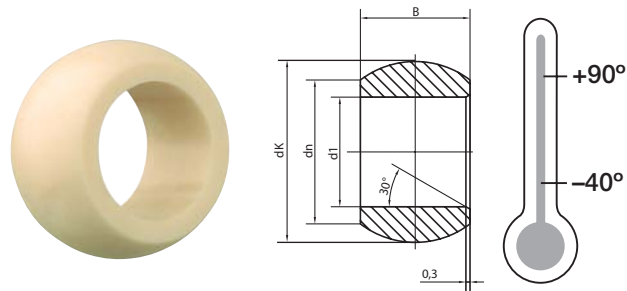
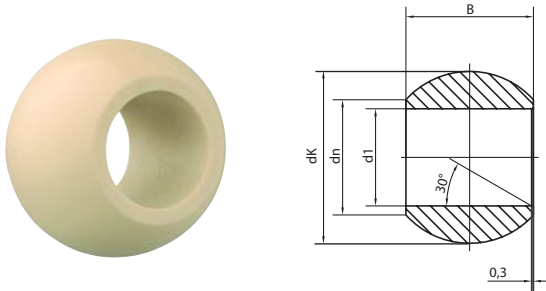

Dimensions (inch)

igubal® Spherical Balls WKI

Part No.	d1 E10	dn	dK	B
WKI-03	.1900	.307	.438	.312
WKI-04	.2500	.354	.516	.375
WKI-05	.3125	.447	.625	.437
WKI-06	.3750	.504	.718	.500
WKI-07	.4375	.601	.828	.562
WKI-08	.5000	.700	.938	.625
WKI-10	.6250	.838	1.125	.750
WKI-12	.7500	.978	1.312	.875
WKI-16	1.0000	1.269	1.750	1.375

Dimensions (inch)

igubal® Spherical Balls WEI

Part No.	d1 E10	dn	dK	B
WEI-03	.1900	.354	.402	.1900
WEI-04	.2500	.314	.402	.2500
WEI-05	.3125	.415	.520	.3125
WEI-06	.3750	.506	.630	.3750
WEI-07	.4375	.581	.709	.4063
WEI-08	.5000	.581	.709	.4063
WEI-10	.6250	.802	.945	.5000
WEI-12	.7500	.951	1.138	.6250
WEI-16	1.0000	1.180	1.398	.7500

Dimensions (mm)

igubal® Spherical Balls WKM

Part No.	d1 E10	dn	dK	B
WKM-02-04	2.00	3.90	5.20	4.00
WKM-03-06	3.00	5.10	7.90	6.00
WKM-05-08	5.00	7.70	11.10	8.00
WKM-06-09	6.00	8.90	12.70	9.00
WKM-08-12	8.00	10.30	15.80	12.00
WKM-10-14	10.00	12.90	19.00	14.00
WKM-12-16	12.00	15.40	22.20	16.00
WKM-14-19	14.00	16.80	25.40	19.00
WKM-16-21	16.00	19.30	28.50	21.00
WKM-18-23	18.00	21.80	31.70	23.00
WKM-20-25	20.00	24.30	34.90	25.00
WKM-22-28	22.00	25.80	38.10	28.00
WKM-25-31	25.00	29.50	42.80	31.00
WKM-30-37	30.00	34.80	51.00	37.00

Dimensions (mm)

igubal® Spherical Balls WEM

Part No.	d1 E10	dn	dK	B
WEM-04-05	4.00	6.25	8.25	5.00
WEM-05-06	5.00	8.00	10.20	6.00
WEM-06-06	6.00	8.00	10.20	6.00
WEM-08-08	8.00	10.00	13.20	8.00
WEM-10-09	10.00	13.00	16.00	9.00
WEM-12-10	12.00	15.00	18.00	10.00
WEM-15-12	15.00	18.00	22.00	12.00
WEM-17-14	17.00	20.00	25.10	14.00
WEM-20-16	20.00	24.00	28.90	16.00
WEM-25-20	25.00	29.00	35.50	20.00
WEM-30-22	30.00	34.00	40.90	22.00

igubal®
Spherical Balls
WKI/WKM
WEI/WEM

PDF: www.igus.com/pdf/igubal.asp
Specs/CAD/RFQ: www.igus.com/igubal.asp
RoHS info: www.igus.com/RoHS.asp



inch

mm

Available from stock

► Tolerance Table, Page 1.14



igubal® Spherical Balls

RKM/REM - XKM/XEM

igubal® Spherical Balls

igubal® Spherical Balls - REI, REM, RKM

Low Cost – iglide® R, low friction values, low cost, low moisture absorption

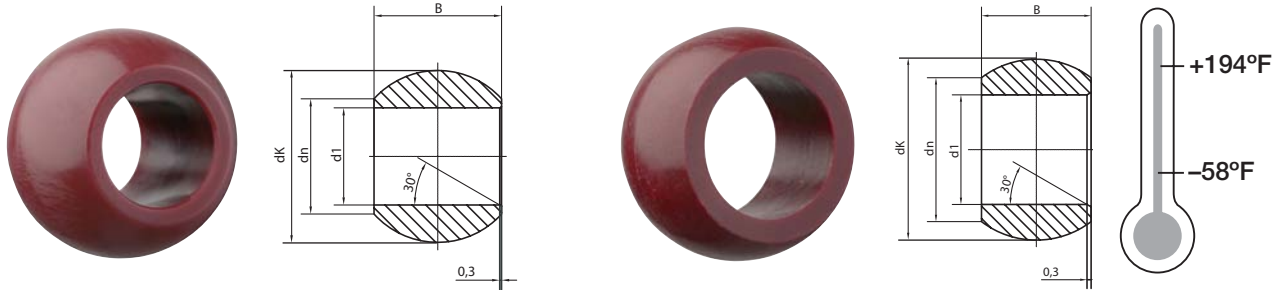

Dimensions (Inch)

igubal® Spherical Bearings REI

Part Number	d1 E10	dn	dK	B
REI-03	.1900	.354	.402	.1900
REI-04	.2500	.314	.402	.2500
REI-05	.3125	.415	.520	.3125
REI-06	.3750	.506	.630	.3750
REI-07	.4275	.581	.709	.4063
REI-08	.5000	.581	.709	.4063
REI-10	.6250	.802	.945	.5000
REI-12	.7500	.951	1.138	.6250
REI-16	1.0000	1.180	1.138	.7500

Dimensions (mm)

igubal® Spherical Bearings REM

Part Number	d1 E10	dn	dK	B
REM-05-06	5.00	8.00	10.20	6.00
REM-06-06	6.00	8.00	10.20	6.00
REM-08-08	8.00	10.00	13.20	8.00
REM-10-09	10.00	13.00	16.00	9.00
REM-12-10	12.00	15.00	18.00	10.00

Dimensions (mm)

igubal® Spherical Bearings RKM

Part Number	d1 E10	dn	dK	B
RKM-10-14	10.00	12.90	19.00	14.00

igubal® Spherical Balls - XKM, XEM

High Temperatures – iglide® T500, resistant to chemicals, high temperatures

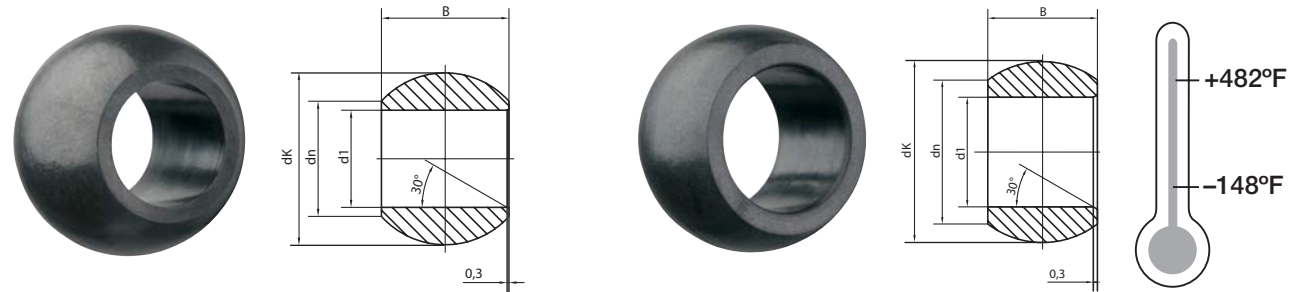

Dimensions (mm)

igubal® Spherical Bearings XKM

Part Number	d1 E10	dn	dK	B
XKM-10-04	10.00	12.90	19.00	14.00

Dimensions (mm)

igubal® Spherical Bearings XEM

Part Number	d1 E10	dn	dK	B
XEM-06-06	6.00	8.00	10.20	6.00
XEM-08-08	8.00	10.00	13.20	8.00
XEM-10-09	10.00	13.00	16.00	9.00
XEM-12-10	12.00	15.00	18.00	10.00

Available for delivery

► Tolerance Table, Page 1.14

Telephone 1-888-803-1895
Fax 1-401-438-7680

Internet: <http://www.igus.com>
E-Mail: sales@igus.com
QuickSpec: www.igus.com/qs/igubal.asp



igubal® Spherical Balls - JKM, JEM

Low moisture absorption – iglide® J; low friction values

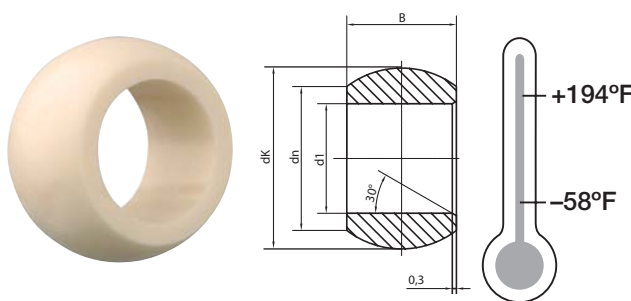
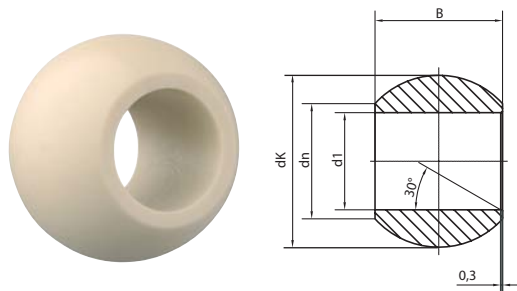

Dimensions (mm)

igubal® Spherical Bearings JKM

Part Number	d1 E10	dn	dK	B
JKM-10-04	10.00	12.90	19.00	14.00

Dimensions (mm)

igubal® Spherical Bearings JEM

Part Number	d1 E10	dn	dK	B
JEM-04-05	4.00	6.25	8.25	5.00
JEM-05-06	5.00	8.00	10.20	6.00
JEM-06-06	6.00	8.00	10.20	6.00
JEM-08-08	8.00	10.00	13.20	8.00
JEM-10-09	10.00	13.00	16.00	9.00
JEM-12-10	12.00	15.00	18.00	10.00
JEM-15-12	15.00	18.00	22.00	12.00
JEM-16-13	16.00	19.50	24.00	13.00
JEM-17-14	17.00	20.00	25.10	14.00
JEM-20-16	20.00	24.00	28.90	16.00
JEM-25-20	25.00	29.00	35.50	20.00
JEM-30-22	30.00	34.00	40.90	22.00

igubal® Spherical Balls - UWEM

Under water applications – iglide® UW

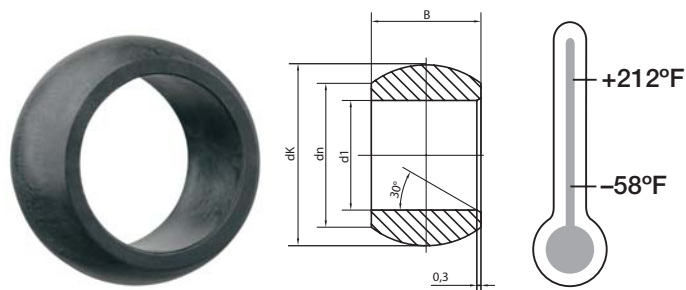

Dimensions (mm)

igubal® Spherical Bearings UWEM

Part Number	d1 E10	dn	dK	B
UWEM-16-13	16.00	19.50	24.00	13.00
UWEM-17-14	17.00	20.00	25.10	14.00
UWEM-25-20	25.00	29.00	35.50	20.00
UWEM-30-22	30.00	34.00	40.90	22.00

igubal®
Spherical Balls
JKM/JEM
UWEM

PDF: www.igus.com/pdf/igubal.asp
Specs/CAD/RFQ: www.igus.com/igubal.asp
RoHS info: www.igus.com/RoHS.asp

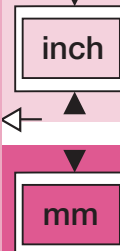
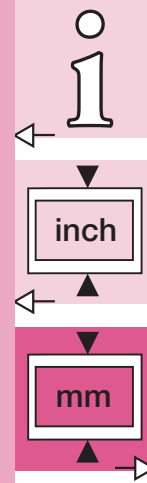



J4VEM

igubal® Spherical Balls

igubal® Spherical Balls

igubal® Spherical Balls -J4VEM

Low moisture absorption – iglide® J4; clearance-free

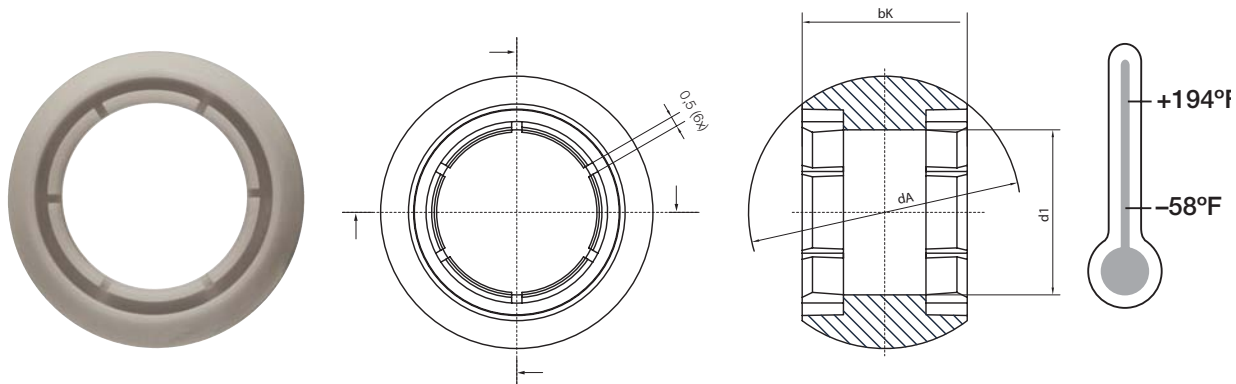

5 Sizes available: Ø 8. 10. 12. 16. 20 mm

combinable with:

igubal® Rod End Bearing	EA(L)RM	➤ Page 28.16
igubal® Rod End Bearing	EB(L)RM	➤ Page 28.18
igubal® Pillow Block Bearing	ESTM	➤ Page 30.7
igubal® Flange Bearing	EFOM	➤ Page 31.7
igubal® Flange Bearing	EFSM	➤ Page 31.5
igubal® Pivoting Bearing	EGFM	➤ Page 32.10
igubal® Pivoting Bearing	EGLM	➤ Page 32.5
igubal® Double Joint	EGZM	➤ Page 32.11

Special Properties

- Can be combined with all housings from design range E
- Sizes 8 to 20 mm
- Pre-loaded
- Totally free from clearance. even in unloaded state
- Material: iglide® J4

Dimensions (mm)

Clearance-free Spherical Bearing

Part Number	d1 E10	dA	bK
J4VEM-08-08	8	13.2	8
J4VEM-10-09	10	16.0	9
J4VEM-12-10	12	18.0	10
J4VEM-16-13	16	24.0	13
J4VEM-20-16	20	28.9	16

Internet: <http://www.igus.com>

E-Mail: sales@igus.com

QuickSpec: www.igus.com/qs/igubal.asp